

**CHAPTER 16  
SUBDIVISION ORDINANCE**

1			
2			
3			
4	<b>Article I.</b>	<b>Purpose, Authority, Scope, Definitions</b>	<b>1</b>
5			
6	<b>Article II.</b>	<b>Review Procedures</b>	<b>7</b>
7	Sec. 16-2-1.	General Procedures	7
8		Public Notice	7
9		Review Escrow Account	8
10	Sec. 16-2-2.	Pre-Application Process	8
11	Sec. 16-2-3.	Review & Approval of Minor Subdivision Plans	8
12	Sec. 16-2-4.	Review & Approval of Major Subdivision Plans	10
13	Sec. 16-2-5.	Amendments to Previously Approved	
14		Subdivision Plans	13
15	Sec. 16-2-6.	Post Approval Requirements	14
16		Performance Guarantee	14
17	Sec. 16-2-7.	Construction Administration	15
18			
19	<b>Article III.</b>	<b>Standards</b>	<b>17</b>
20	Sec. 16-3-1.	Subdivision Review Standards	17
21	Sec. 16-3-2.	Road Design & Construction Design	24
22		Road Classification Standards Table	32
23	Sec. 16-3-3.	Design of Other Improvements	32
24	Sec. 16-3-4.	Additional Standards	33
25	Sec. 16-3-5.	Waivers	33
26	Sec. 16-3-6	Legal Provisions	34
27			
28	<b>Appendix A.</b>	Minor Subdivision Submission list	35
29	<b>Appendix B.</b>	Major Subdivision Submission list	38
30	<b>Appendix C.</b>	Road Tree List	44
31	<b>Appendix D.</b>	Turnaround designs	45
32	<b>Appendix E.</b>	Road Design Cross Sections	47

**ARTICLE I. Purpose, Authority, Scope, Definitions.**

**Sec. 16-1-1. Purpose.** This Ordinance is designed to promote the health, safety, convenience and general welfare of the Inhabitants of the Town of Cape Elizabeth by encouraging and ensuring sound planning, the use of the environment under healthful conditions, the imaginative and orderly use of land, compliance with the goals and objectives of the Comprehensive Plan, and development that fits harmoniously into the existing natural environment and rural character.

1 **Sec. 16-1-2. Authority.** This Ordinance shall apply to all land within the limits of the  
2 Town of Cape Elizabeth, Cumberland County, Maine and shall be administered by the  
3 Planning Board of the Town of Cape Elizabeth, hereinafter called “the Planning Board”,  
4 and the Town’s designated staff.

5 **Sec. 16-1-3 Scope.**

6  
7 (a) Any person, firm, corporation or other legal entity proposing to sell, lease or  
8 convey, or to offer or agree to sell, lease or convey, any land in a subdivision any  
9 portion of which is within the limits of the Town of Cape Elizabeth, shall first  
10 submit such subdivision for approval by the Planning Board in accordance with  
11 this Ordinance and shall record in the Cumberland County Registry of Deeds a  
12 plan thereof bearing the approval of the Planning Board.

13  
14 (b) No utility installations; no ditching, grading or construction of roads; no grading  
15 of land or lots; and no construction of buildings shall be done on any part of the  
16 proposed subdivision until a subdivision application has been submitted, reviewed  
17 and finally approved as provided by this Ordinance.

18  
19 **Sec. 16-1-4 Definitions.**

20  
21 In general, words and terms used in this Ordinance shall have their customary dictionary  
22 meanings, but the following words and terms as used in this Ordinance are defined as  
23 follows:

24 **“Applicant”** - the record owner, or a person having an interest in the land either through  
25 written option or contract.

26 **“Access Road”** - any road which includes (1) an eighteen (18) feet wide traveled way,  
27 (2) deeded and actual rights of public emergency access, and (3) year-round maintenance,  
28 including snow plowing of the road, the responsibility of which is documented in a  
29 binding written agreement if the road is not located within a public right-of-way.

30 **“Arterial”** - a road which is a major link with other communities. This road typically  
31 averages in excess of three thousand (3,000) trips per day with an average length of each  
32 trip of more than one mile. Arterials accommodate residential, agricultural and most of  
33 the Town’s commercial development. Direct access by residential development should be  
34 discouraged, and commercial access should be combined with adjacent commercial uses  
35 where feasible.

36 **“AASHTO”** - the American Association of State Highway and Transportation Officials,  
37 an organization that establishes transportation specifications.

38 **“Building Envelope”** - the area within a lot where the main and accessory buildings shall  
39 be located.

40 **“Cluster Development”** - a type of subdivision development for single family detached  
41 dwellings, multiplex dwellings, or a combination of both, where lot sizes, lot widths, and  
42 building setbacks are reduced below the minimum requirements of this Ordinance and the  
43 land gained thereby is set aside as open space.

1     **“Collector”** - a road that collects traffic from the most densely settled areas and  
2 typically connects to an adjacent community. This road averages in excess of two  
3 thousand (2,000) trips per day with an average length of each trip over more than one  
4 mile. Collectors are located in areas with a dense, suburban pattern of development. The  
5 design of collectors must provide heavy traffic flow capacity and protect sensitive scenic  
6 areas and neighborhoods. Direct access by single driveway should be discouraged.

7     **“Dead-end road”** - a road with a single, common means of ingress and egress.  
8 [Rev. eff. 7/13/94]

9  
10    **“Ditch”** - a channel for conveying surface water outside the traveled way.

11  
12    **“Dwelling unit”** - any part of a structure which, through sale or lease, is intended for  
13 human habitation, including single-family and multi-family housing, condominiums,  
14 apartments and time-share units.

15  
16    **“Easement”**- a grant of one or more of the property rights by the property owner to  
17 and/or for use by the public, a corporation, or another person or entity. Examples of  
18 easements include but are not limited to drainage, conservation, emergency access,  
19 pedestrian, utility, road and open space easements.

20  
21    **“Emergency Access Lane”**- a public or private paved road with a minimum width of  
22 eighteen (18) feet which is not open to through vehicular traffic. This type of road may  
23 provide secondary emergency access to an area served by a dead-end road. [Rev. eff.  
24 6/12/91]

25  
26    **“Esplanade”** - a landscaped strip of land located between a road and a sidewalk or  
27 between two roads.

28    **“Farmland”** - a parcel consisting of five (5) or more acres of land that is (1) classified as  
29 prime farmland, unique farmland or farmland of statewide or local importance by the  
30 Natural Resources Conservation Service within the United States Department of  
31 Agriculture; or (2) used for the production of agricultural products as defined in Title 7  
32 M.R.S.A. Sec. 152, subsection 2.

33    **“Feeder”** - a road that connects local roads to other roads. This road is typically densely  
34 developed and serves more than one-hundred (100) dwellings or approximately one-  
35 thousand (1,000) trips per day. Feeders primarily serve residential traffic where access by  
36 single driveway is common.

37    **“Local Road”** - a road that provides direct access to adjacent residential land or the  
38 Town center area. The local road is the most common road classification and carries a  
39 low volume of trips in residential areas, although higher volumes are also common in the  
40 Town center area. Local roads should be designed for slow speeds and frequent  
41 pedestrian travel.

42    **“Lot”** - an area of land in one ownership, regardless of the dates or sources of acquisition  
43 thereof and regardless of the buildings and uses existing thereon, having definite  
44 boundaries by recorded plan or deed and having an area of less than forty (40) acres.

1     **“Manufactured Housing Unit”** - structures, transportable in one or more sections,  
2     which were constructed in a manufacturing facility and are transported to a building site  
3     and designed to be used as dwellings when connected to the required utilities, including  
4     the plumbing, heating, air conditioning and electrical systems contained therein.

5     **“Manufactured Housing Park”** - a parcel of land under unified ownership designed  
6     and/or used to accommodate three or more manufactured housing units.

7     **“Manufactured Housing Park Lot”** - the area of land on which an individual home is  
8     situated within a manufactured housing park and which is reserved for use by the  
9     occupants of that home.

10    **“MDOT”** - the State of Maine Department of Transportation.

11    **“M.R.S.A”** - Maine Revised Statutes Annotated.

12    **“MUTCD”** - the Manual on Uniform Traffic Control Device Standards.

13    **“Multiplex Housing”** - attached dwelling units, as defined in the Zoning Ordinance  
14    (Chapter 19).

15    **“Performance Guarantee”** - any security that may be accepted by the Town to assure  
16    that improvements required as part of an application for development will be completed  
17    in compliance with the approved plans.

18    **“Planner”** - that person designated by the Town to assist the Planning Board in its  
19    subdivision and site plan review.

20    **“Planning Board Decision”** - the Planning Board vote to approve or conditionally  
21    approve the preliminary or final plan.

22    **“Principal Structure”** - any building other than one that is used for purposes wholly  
23    incidental or accessory to the use of another building on the same premises.

24    **“Private Road”** - a road or way that provides access to more than one principal structure  
25    and which is not owned by the Town.

26    **“Resubdivision”** - the replatting of all or part of the land included in a subdivision plan  
27    already approved by the Planning Board.

28    **“Right-of-way”**- (1) a strip of land acquired by conveyance, reservation, dedication,  
29    forced dedication, prescription or condemnation and intended to be occupied by a road,  
30    sidewalk, crosswalk, railroad, electric transmission lines, oil or gas pipeline, water line,  
31    sanitary storm sewer, or other similar uses; (2) generally, the right of one to pass over the  
32    property of another.

33    **“Road”** - a public or private way for vehicular traffic however designated, serving more  
34    than one residential unit or more than one lot.

35    **“Rural Connector”** - a road that handles trips between different parts of Town and  
36    connects rural residential development to arterials. This road typically carries less than  
37    (1,000) trips per day with an average length of more than one (1) mile. Rural connectors  
38    are located in primarily rural residential areas and the rural character should be  
39    maintained. Access by residential development should preferably be by a local road, but  
40    may be from a single driveway.

1    **“Sight Distance”** - see Section 16-3-2 (a) (1) of this Ordinance.

2    **“Site Improvement”** - all changes and construction required of a subdivision to be in  
3 compliance with Planning Board approval and Town Standards.

4    **“Spaghetti lot”** - any lot in a proposed subdivision with shore frontage on a river,  
5 stream, brook, great pond, or coastal wetland, as these features are defined in Title 38  
6 M.R.S.A. Section 480(B), with a lot depth to shore frontage ratio greater than 5 (five) to  
7 1 (one).

8    **“Standard Boundary Survey”** - a map of a quantity of real estate prepared by a  
9 professional land surveyor registered in the State of Maine and based on (1) adequate  
10 research to support a professional opinion of boundary location, (2) field work including  
11 an inspection of the real estate and (3) the preparation of a plan, drawn to scale and  
12 including property boundary lines, easements and rights-of-way and existing structures,  
13 suitable for recording.

14  
15    **“Structure”** - anything constructed or erected with a fixed location on or in the ground,  
16 or attached to something having a fixed location on or in the ground, including, but not  
17 limited to, buildings, mobile homes, retaining walls, billboards, signs, piers and floats. It  
18 does not include a wharf, fish weir or trap that may be licensed under Title 38 M.R.S.A.  
19 Sections 1021-1027. A new structure or structures includes any structures for which  
20 construction begins on or after September 23, 1988. The area included in the expansion  
21 of an existing structure is deemed to be a new structure for the purposes of the  
22 Subdivision Ordinance.

23    **“Subdivision”** - the division of a tract or parcel of land into three (3) or more lots within  
24 any five (5) year period, which period begins after September 22, 1971, whether  
25 accomplished by sale, lease, development, buildings or otherwise. The term  
26 “subdivision” also includes the division of a new structure or structures on a tract or  
27 parcel of land into three (3) or more dwelling units within a five (5) year period, the  
28 construction or placement of three (3) or more dwelling units on a single tract or parcel of  
29 and the division of an existing structure or structures previously used for commercial or  
30 industrial use into three (3) or more dwelling units within a five (5) year period.

31        A. In determining whether a tract or parcel of land is divided into three (3) or more  
32 lots, the first dividing of such tract or parcel is considered to create the first two  
33 (2) lots and the next dividing of either of said first two lots, by whomever  
34 accomplished, is considered to create a third lot, unless:

35           (1) Both dividings are accomplished by a subdivider who has retained one of the  
36 lots for the subdivider’s own use as a single family residence for a period of at  
37 least five (5) years immediately preceding the second division: or

38           (2) The division of the tract or parcel is otherwise exempt under subsection D  
39 below.

40        B. The dividing of a tract or parcel of land and the lot or lots so made, which  
41 dividing or lots when made are not subject to the Ordinance, do not become  
42 subject to the Ordinance by the subsequent dividing of that tract or parcel of land  
43 or any portion of that tract or parcel of land. The municipal reviewing authority

1 shall consider the existence of the previously created lot or lots in reviewing a  
2 proposed subdivision created by a subsequent dividing.

3 C. A lot of forty (40) or more acres shall not be counted as lots when the lot is  
4 located entirely outside of the Shoreland Performance Overlay District.

5 D. Exceptions.

6 (1) A division accomplished by devise does not create a lot or lots for the  
7 purposes of this definition, unless the intent of the transferor is to avoid the  
8 objectives of the Ordinance.

9 (2) A division accomplished by condemnation does not create a lot or lots for the  
10 purposes of this definition, unless the intent of the transferor is to avoid the  
11 objectives of the Ordinance.

12 (3) A division accomplished by order of court does not create a lot or lots for the  
13 purposes of this definition, unless the intent of the transferor is to avoid the  
14 objectives of the Ordinance.

15 (4) A division accomplished by gift to a person related to the donor of an interest  
16 in property held by the donor for a continuous period of five (5) years prior to  
17 the division by gift does not create a lot or lots for the purposes of this  
18 definition, unless the intent of the transferor is to avoid the objectives of the  
19 Ordinance. If the real estate exempt under this definition is transferred within  
20 five (5) years to another person not related to the donor of the exempt real  
21 estate as provided in this paragraph, then the previously exempt division  
22 creates a lot or lots for the purposes of the Ordinance. "Person related to the  
23 donor" means a spouse, parent, grandparent, brother, sister, child or  
24 grandchild related by blood, marriage or adoption. A gift under this definition  
25 can not be given for consideration that is more than one-half (1/2) the assessed  
26 value of the real estate.

27 (5) A division accomplished by a gift to a municipality if that municipality  
28 accepts the gift does not create a lot or lots for the purposes of this definition,  
29 unless the intent of the transferor is to avoid the objectives of the Ordinance.

30 (6) A division accomplished by the transfer of any interest in land to the owners  
31 of land abutting that land does not create a separate lot does not create a lot or  
32 lots for the purposes of this definition, unless the intent of the transferor is to  
33 avoid the objectives of the Ordinance. If the real estate exempt under this  
34 paragraph is transferred within five (5) years to another person without all of  
35 the merged land, then the previously exempt division creates a lot or lots for  
36 the purposes of the Ordinance.

37 (7) The grant of a bona fide security interest in an entire lot that has been  
38 exempted from the definition of subdivision under subsection D above, or  
39 subsequent transfer of that entire lot by the original holder of the security  
40 interest or that person's successor in interest, does not create a lot for the  
41 purposes of this definition, unless the intent of the transferor is to avoid the  
42 objectives of the Ordinance.

1 E. The division of a tract or parcel of land into three (3) or more lots and upon each  
2 of which lots permanent dwelling structures legally existed before September 23,  
3 1971 is not a subdivision.

4 F. In determining the number of dwelling units in a structure, the provisions of the  
5 Ordinance regarding the determination of the number of lots apply, including  
6 exemptions from the definition of a subdivision of land.

7 G. Notwithstanding the provisions of the Ordinance, leased dwelling units are not  
8 subject to subdivision review if the municipal reviewing authority has determined  
9 that the units are otherwise subject to Site Plan Review under the Zoning  
10 Ordinance.

11 **“Major Subdivision”** - a subdivision containing more than five (5) lots, or requiring  
12 substantial extension of municipal facilities or any new public road.

13 **“Minor Subdivision”** - a subdivision containing not more than five (5) lots and is not  
14 otherwise defined as a major subdivision.

15 **“Through road”** - a road with more than one means of ingress or egress. Both means of  
16 ingress and egress must, at a minimum, meet the standards of an access road.

17 **“Tract or parcel of land”**- tract or parcel of land means all contiguous land in the same  
18 ownership, except that lands located on opposite sides of a public or private road are  
19 considered each a separate tract or parcel of land unless the road was established by the  
20 owner of land on both sides of the road after September 22, 1971.

21 **“Town Engineer”**- that person designated by the Town to provide engineering advice to  
22 the Planning Board in its subdivision and site plan review.

23 **“Traveled Way”** - that portion of a right-of-way which is regularly used for vehicular  
24 traffic.

25 **Article II. Review Procedures**

26 **Sec. 16-2-1. General Procedures.** In all stages of the subdivision review process, the  
27 burden of proof shall be upon the applicant proposing the subdivision.

28 (a) **Public Record.** The Planning Board shall maintain a permanent record of all its  
29 meetings, proceedings and correspondence. The Planning Board shall specify in writing  
30 its decisions and findings of fact.

31 (b) **Public Notice.** When notice to abutters is required, the Planner shall cause notice  
32 to be given by mail to the owners, as currently listed by the Town Tax Assessor, of all  
33 properties within 500’ of the proposed project property line boundary. If the project abuts  
34 an adjacent municipality, the Planner shall notify the adjacent municipality’s planning  
35 staff and request that all pertinent property owners be notified of the project proposal.  
36 Such notice shall include the date, time and location of the meeting and the location and  
37 general description of the proposed development.

38 If a public hearing is scheduled, mailed notice shall be provided as described above. In  
39 addition, the Planner shall cause notice of the date, time and place of the hearing to be  
40 published at least two (2) times in a newspaper having general circulation in the Town of

1 Cape Elizabeth. The date of the first publication must be at least seven (7) days before the  
2 public hearing.

3 **(c) Review Escrow Account.** In addition to the application fees set by the Town  
4 Council, a Review Escrow Fee to defray the Town's costs for application review by the  
5 Town Engineer and/or other independent consulting services shall be provided. The fee  
6 shall be recommended by the Town Engineer or consultant and approved by the Town  
7 Manager upon initial review of the application and paid to the Town by the applicant  
8 prior to the next meeting with the Planning Board. The fee shall be deposited in a Review  
9 Escrow Account designated for that application. If the costs of application review by the  
10 Town Engineer and/or other consulting services exceed the amount of the Review  
11 Escrow Account, the applicant shall pay an additional fee to the Town that shall be  
12 recommended by the Town Engineer or consultant and approved by the Town Manager  
13 based upon the status of the application. Any balance in the account remaining after a  
14 final decision on the application by the Planning Board and satisfaction of any approval  
15 conditions shall be returned to the applicant unless there is an appeal or other legal action  
16 pending with respect to the Planning Board's approval. All interest from the Review  
17 Escrow Account shall accrue to the account and shall be applied toward the Town's cost  
18 in reviewing the application.

19  
20 **(d) Duration of Time.** Unless otherwise specified, number of days shall be  
21 calculated as calendar days.

22  
23 **Sec. 16-2-2. Pre-Application Process.** Prior to submitting an application for subdivision  
24 review, the applicant shall meet with the Planning Board at a workshop at least once to  
25 discuss the proposal generally, acquaint the Planning Board with the nature of the  
26 proposal and the location, topography and other attributes of its site, review potential  
27 submission waivers and obtain preliminary classification of the proposal as either a minor  
28 or major subdivision. The Planner shall arrange for public notice of the meeting in  
29 accordance with Sec. 16-2-1(b) of this Ordinance.

30 **Sec. 16-2-3. Review and Approval of Minor Subdivisions**

31 **(a) Procedures.**

- 32 1. Formal Submission. The subdivision applicant or an agent duly authorized in writing,  
33 shall submit to the Planner a subdivision application for consideration by the Planning  
34 Board together with the fee therefore as prescribed by the Town Council, and  
35 fourteen (14) complete copies of the proposed subdivision plans and materials. All  
36 plans and materials shall be submitted at least eighteen (18) days prior to the Planning  
37 Board's next scheduled meeting. Prior to the first meeting with the Planning Board,  
38 the applicant shall also establish a Review Escrow Account under the terms in Sec.  
39 16-2-1(c) of this Ordinance.
- 40  
41 2. Preliminary Completeness. Within thirty (30) days of the receipt of a subdivision  
42 application and accompanying materials, the Planner, in consultation with the  
43 Planning Board Chair, shall make a preliminary determination as to completeness. If  
44 the application is preliminarily determined to be incomplete, the Planner shall so  
45 notify the applicant in writing and shall list in the written determination the materials



1 that must be submitted in order to make the application complete. If an applicant fails  
2 to submit a complete application within four (4) months of the date of the Planner's  
3 preliminary written determination, the application shall be deemed withdrawn. When  
4 the Planner makes the preliminary determination that an application is complete, the  
5 application shall be scheduled for consideration at the next available Planning Board  
6 meeting. Once scheduled, the Planner shall promptly notify the applicant of the time  
7 and place of such meeting. No action taken by the Planner, either alone or in  
8 consultation with the Planning Board Chair, with respect to reviewing a subdivision  
9 application, shall result in an application being deemed pending for the purposes of  
10 Title 1 M.R.S.A. Sec. 302. The Planner, either alone or in consultation with the  
11 Planning Board Chair, shall have no authority to review the substance of a  
12 subdivision application to determine whether it complies with the subdivision review  
13 criteria.

- 14
- 15 3. Public Notice. The Planner shall arrange for public notice of the meeting in  
16 accordance with Sec. 16-2-1 (b) of this Ordinance.
- 17 4. Planning Board Completeness. At its first meeting for consideration of an application  
18 for approval of a subdivision, the Planning Board shall determine whether the  
19 application is complete or incomplete. Within seven (7) days of the first regular  
20 meeting, the Planning Board shall provide to the applicant a dated letter  
21 acknowledging receipt of the application and the Planning Board's determination as  
22 to completeness. If the application is determined to be incomplete, the Planning  
23 Board shall list in its written determination the materials that must be submitted in  
24 order to make the application complete. If an applicant fails to submit a complete  
25 application within four (4) months of the Planning Board letter or within four (4)  
26 months of the written determination of the Planner, the application shall be deemed  
27 withdrawn, unless said time limitation is otherwise extended by the Planning Board  
28 for good cause. When the application is deemed complete, the Planning Board shall  
29 begin review of the proposed subdivision.
- 30 5. Site Walk. One or more site walks may be scheduled by the Planning Board. The  
31 applicant shall provide temporary markers of key subdivision elements, such as but  
32 not limited to road centerlines and wetland boundaries, on the site prior to the site  
33 walk at the request of the Planning Board.
- 34
- 35 6. Public Hearing. The Planning Board shall hold a public hearing on a minor  
36 subdivision application within thirty (30) days of the date that the application is  
37 determined to be complete. Public notice shall be provided in accordance with  
38 Section 16-2-1(b) of this Ordinance.

39

40 The Planning Board shall conduct the hearing as to assure full, but not repetitive,  
41 public participation. The applicant shall be prepared to respond fully to questioning  
42 by the public and the Planning Board. The Planning Board may, upon its own motion,  
43 extend the hearing once for a period not exceeding thirty (30) days and to a date that  
44 shall be announced.

1 7. Planning Board Decision. The Planning Board shall approve, or approve with  
2 conditions, or disapprove the Subdivision Plan: (i) within sixty (60) days from the  
3 date of the date that the application is determined to be complete, or (ii) within such  
4 other time that may be mutually agreed upon by both the Planning Board and the  
5 applicant.  
6

7 **(b) Submission Requirements.** Minor Subdivision Plan submissions shall conform  
8 to the standards and requirements contained in Appendix A of this Ordinance.  
9

10 **Sec. 16-2-4. Review and Approval of Major Subdivision Plans.**  
11

12 **(a) Preliminary Plan Procedures.**

13 1. Formal Submission. The subdivision applicant, or an agent duly authorized in writing,  
14 shall submit to the Planner a subdivision application for consideration by the Planning  
15 Board together with the fee therefore as prescribed by the Town Council, and  
16 fourteen (14) complete copies of the proposed preliminary subdivision plans and  
17 materials. All plans and materials shall be submitted at least eighteen (18) calendar  
18 days prior to the Planning Board's next scheduled meeting. Prior to the first meeting  
19 with the Planning Board, the applicant shall also establish a Review Escrow Account  
20 under the terms in Sec. 16-2-1(c) of this Ordinance.  
21

22 2. Preliminary Completeness. Within thirty (30) days of the receipt of a preliminary  
23 subdivision application and accompanying materials, the Planner, in consultation with  
24 the Planning Board Chair, shall make a preliminary determination as to completeness.  
25 If the application is preliminarily determined to be incomplete, the Planner shall so  
26 notify the applicant in writing and shall list in the written determination the materials  
27 that must be submitted in order to make the application complete. If an applicant fails  
28 to submit a complete application within four (4) months of the date of the Planner's  
29 preliminary determination, the application shall be deemed withdrawn. When the  
30 Planner makes the preliminary determination that an application is complete, the  
31 application shall be scheduled for consideration at the next available Planning Board  
32 Meeting. Once scheduled, the Planner shall promptly notify the applicant of the time  
33 and place of such meeting. No action taken by the Planner, either alone or in  
34 consultation with the Planning Board Chair, with respect to reviewing a subdivision  
35 application, shall result in an application being deemed pending for the purposes of  
36 Title 1 M.R.S.A. Section 302. The Planner, either alone or in consultation with the  
37 Planning Board Chair, shall have no authority to review the substance of a  
38 subdivision application to determine whether it complies with the subdivision review  
39 criteria.  
40

41 3. Public Notice. The Planner shall arrange for public notice of the meeting in  
42 accordance with Sec. 16-2-1(b) of this Ordinance.  
43

44 4. Planning Board Completeness. At its first meeting for consideration of an application  
45 for preliminary approval of a subdivision, the Planning Board shall determine

1 whether the application is complete or incomplete. Within seven (7) days of the first  
2 regular meeting, the Planning Board shall provide to the applicant a dated letter  
3 acknowledging receipt of the application and the Planning Board's determination of  
4 completeness. If the application is determined to be incomplete, the Planning Board  
5 shall list in its written determination the materials that must be submitted in order to  
6 make the application complete. If an applicant fails to submit a complete application  
7 within four (4) months of the Planning Board letter or within four (4) months of the  
8 written determination of the Planner, the application shall be deemed withdrawn  
9 unless said time limitation is otherwise extended by the Planning Board for good  
10 cause. When the application is deemed complete, the Planning Board shall begin  
11 review of the proposed subdivision.  
12

- 13 5. Site Walk. One or more site walks may be scheduled by the Planning Board. The  
14 applicant shall provide temporary markers of key subdivision elements, such as but  
15 not limited to road centerlines and wetland boundaries, on the site prior to the site  
16 walk at the request of the Planning Board.  
17
- 18 6. Public Hearing. The Planning Board shall hold a public hearing on a major  
19 subdivision application within thirty (30) days of the date that the preliminary  
20 subdivision application is determined to be complete. Public notice shall be provided  
21 in accordance with Sec. 16-2-1(b) of this Ordinance.  
22

23 The Planning Board shall conduct the hearing as to assure full, but not repetitive,  
24 public participation. The applicant shall be prepared to respond fully to questioning  
25 by the public and the Planning Board. The Planning Board may, upon its own motion,  
26 extend the hearing once for a period not exceeding thirty (30) days and to a date that  
27 shall be announced.

- 28 7. Planning Board Decision. The Planning Board shall approve, or approve with  
29 conditions, or disapprove the Preliminary Plan: (i) within thirty (30) days after the  
30 date of the public hearing, or (ii) within such other time that may be mutually agreed  
31 upon by both the Planning Board and the applicant. Preliminary Plan approval shall  
32 not constitute approval of the Final Plan, but rather shall be deemed an expression of  
33 approval of the approach submitted on the Preliminary Plan as a guide to preparation  
34 of the Final Plan.  
35

36 **(b) Preliminary Plan Submission Requirements.**

37 Preliminary Plan submissions shall conform to the standards and requirements contained  
38 in Appendix B of this Ordinance.

39 **(c) Final Plan Procedures.**

- 40 1. Formal Submission. Within six (6) months following the Planning Board's approval  
41 or approval with conditions of an applicant's Preliminary Plan, the applicant shall file  
42 with the Planner for Planning Board consideration, a Final Plan application for the  
43 subdivision with fourteen (14) copies of the materials herein prescribed. If such  
44 application is not filed within such period, the application shall be deemed withdrawn

1 and shall no longer be considered a pending subdivision application, unless said time  
2 limitation is otherwise extended by the Planning Board for good cause.

- 3
- 4 2. Final Subdivision Plan Preliminary Completeness. Within thirty (30) days of the  
5 receipt of a final subdivision application and accompanying materials, the Planner in  
6 consultation with the Planning Board Chair, shall make a preliminary determination  
7 of completeness. If the application is preliminarily determined to be incomplete, the  
8 Planner shall so notify the applicant in writing and shall in the written determination  
9 the materials that must be submitted in order to make the application complete. If an  
10 applicant fails to submit a complete application within four (4) month of the date of  
11 the Planner's preliminary written determination, the application shall be deemed  
12 withdrawn. When the Planner makes the preliminary determination that an  
13 application is complete, the application shall be scheduled for consideration at the  
14 next available Planning Board meeting. Once scheduled, the Planner shall promptly  
15 notify the applicant of the time and place of such meeting. No action taken by the  
16 Planner, either alone or in consultation with the Planning Board Chair, with respect to  
17 reviewing a subdivision application, shall result in an application being deemed  
18 pending for the purposes of Title 1 M.R.S.A. Sec. 302. The Planner, either alone or in  
19 consultation with the Planning Board Chair, shall have no authority to review the  
20 substance of a subdivision application to determine whether it complies with the  
21 subdivision review criteria.
- 22
- 23 3. Public Notice. Once a Planning Board meeting is scheduled, the Planner shall also  
24 cause notice to be given per Sec. 16-2-1(b) of this Ordinance.
- 25
- 26 4. Planning Board Final Subdivision Plan Completeness. At its first meeting for  
27 consideration of an application for final approval of a subdivision, the Planning Board  
28 shall determine whether the application is complete or incomplete. Within seven (7)  
29 days of the first regular meeting, the Planning Board shall provide to the applicant a  
30 dated letter acknowledging receipt of the application and the Planning Board's  
31 determination of completeness. If the application is determined to be incomplete, the  
32 Planning Board shall list in its written determination the materials that must be  
33 submitted in order to make the application complete. If an applicant fails to submit a  
34 complete application within four (4) months of the Planning Board letter or within  
35 four (4) months of the written determination of the Planner, the application shall be  
36 deemed withdrawn and shall no longer be considered a pending subdivision  
37 application, unless said time limitations is otherwise extended by the Planning Board  
38 for good cause. When the application is deemed complete, the Planning Board shall  
39 begin review of the proposed subdivision.
- 40
- 41 5. Site walk. One or more site walks may be scheduled by the Planning Board. The  
42 applicant shall provide temporary markers of key subdivision elements, such as but  
43 not limited to road centerlines and wetland boundaries, on the site prior to the site  
44 walk at the request of the Planning Board.
- 45

1 6. Public Hearing. The Planning Board may schedule a public hearing on the final  
2 Subdivision plan if it considers any changes in the plan sufficient to warrant further  
3 public comment. Public notice shall be given in accordance with Section 16-2-1 (b) of  
4 this Ordinance.

5  
6 If a public hearing is held, the Planning Board shall conduct the hearing as to assure  
7 full, but not repetitive, public participation. The applicant shall be prepared to  
8 respond fully to questioning by the public and the Planning Board. The Planning  
9 Board may, upon its own motion, extend the hearing once for a period not exceeding  
10 thirty (30) days and to a date which shall be announced.

11  
12 7. Planning Board Decision. The Planning Board shall approve, or approve with  
13 conditions or disapprove the Final Subdivision Plan: (i) within thirty (30) days of the  
14 date of the public hearing; (ii) within sixty (60) days of the date that the application  
15 was determined to be complete if no public hearing is held; or (iii) within such other  
16 time that may be mutually agreed upon by both the Planning Board and the applicant.

17  
18 **(d) Final Plan Submission Requirements.** Final Subdivision Plan submissions shall  
19 conform to the standards and requirements contained in Appendix B of this Ordinance.

20 **Sec. 16-2-5. Amendments to Previously Approved Subdivision Plans**

21 **(a) Scope.** Any change in an approved final subdivision plan including but not limited to  
22 lot lines, road layout, and location of structures and improvements must be reviewed  
23 and approved by the Planning Board. De minimus changes to an approved  
24 subdivision plan may be placed on the Planning Board Consent Agenda at the  
25 discretion of the Planner.

26 **(b) De minimus Changes.** De minimus changes shall not include (1) an increase in the  
27 number of lots or units, (2) a change to a public or private right-of way or easement,  
28 (3) a decrease in proposed buffering or landscaping, or (4) any issue involving a  
29 condition placed on the Subdivision approval. Prior to placement on the Consent  
30 Agenda, the applicant shall meet with the Planner to review the proposed changes and  
31 shall provide eight (8) copies of the revised recording plat to the Planner at least  
32 eighteen (18) days prior to the next regular Planning Board meeting. The decision of  
33 the Planner to not place an item on the Consent Agenda may be appealed to the  
34 Planning Board upon submission of fourteen (14) copies of the proposed change to  
35 the Planner eighteen (18) days prior to the next Planning Board meeting.

36 **(c) Procedure.** A public hearing may be held concerning a subdivision amendment as  
37 prescribed in Sec. 16-2-1(b) of this Ordinance. The Planning Board may request the  
38 submission of information included in Appendix A or B and shall review the  
39 subdivision amendment for compliance with the standards in Sec. 16-3-1 of this  
40 Ordinance. All amended plans must make specific reference to the original plan and  
41 its recording information. The Planning Board Decision shall be to approve, approve  
42 with conditions or deny the subdivision amendment.

43 **(d) Subdivision vacation.** Once a subdivision has been recorded, a subdivision where no  
44 lots have been sold or the entire subdivision is owned by one entity and no alteration  
45 to commence the subdivision has occurred on the site, may be vacated in its entirety  
46 by a vote of the Town Council at the request of the subdivision owner. Anything less

1 than a complete vacation of the subdivision must be submitted to the Planning Board  
2 as an amendment. Approval by the Town Council to vacate the subdivision must be  
3 recorded in the Cumberland County Registry of Deeds.  
4

5 **Sec. 16-2-6. Post Approval Requirements.**

6 **(a) Satisfaction of Planning Board Conditions of Approval.** Following the Planning  
7 Board Decision, the subdivision plans and materials shall be revised by the applicant  
8 to comply with any conditions placed on the approval by the Planning Board. Two (2)  
9 sets of revised plans shall be submitted to the Planner. The Planner, and other town  
10 staff as necessary, shall review all plans for compliance with the Planning Board  
11 conditions of approval. The Planner shall determine whether the plans have been  
12 revised to comply with the Planning Board approval. If the applicant fails to obtain  
13 confirmation from the Planner that the plans are in compliance with the conditions  
14 placed on the approval, the applicant may submit the revised subdivision plans to the  
15 Planning Board in accordance with Sec. 16-2-3(a)(1) of this Ordinance for minor  
16 subdivisions or Sec. 16-2-4(c)(1) of this Ordinance for major subdivisions.

17 **(b) Plan Recording.** Once the plans are determined to be in compliance with the  
18 Planning Board approval, the recording plan shall be properly signed by a majority of  
19 the Planning Board, and shall be recorded by the subdivider in the Cumberland  
20 County Registry of Deeds. If the subdivision approval includes phasing of the  
21 subdivision, the recording plan shall depict all phases of the subdivision. Any final  
22 plans not so recorded within ninety (90) days following the date of Planning Board  
23 Decision shall become null and void. The applicant may request, prior to the  
24 expiration date, that the Planning Board grant an extension due to particular  
25 circumstances of the applicant which extension shall not exceed an additional period  
26 of ninety (90) days. Once recorded, the subdivider shall provide the Planner with  
27 three (3) paper copies of the subdivision plat with the Planning Board signatures and  
28 the book and page recording information from the Registry of Deeds.  
29

30 **(c) Performance Guarantee.** There shall be no sale of lots, nor building permits issued,  
31 nor site work commenced until a Performance Guarantee has been approved by and  
32 posted with the Town of Cape Elizabeth Town Manager.  
33

34 1. Form. The Performance Guarantee shall be in the form of an irrevocable letter  
35 of credit or escrow account in favor of the Town. Such Performance Guarantee  
36 shall be satisfactory to the Town Manager and to the Town Attorney as to the  
37 issuer, substantive sufficiency, surety and manner of execution. All performance  
38 guarantees shall contain a provision requiring the issuer to notify the Town  
39 Manager in writing of the scheduled expiration date at least thirty (30) days and  
40 not more than ninety (90) days in advance of its scheduled expiration date.  
41 Extensions of the Performance Guarantee may be granted by the Town Manager  
42 for up to three (3) years from the initial expiration date at the request of the  
43 applicant for good cause.  
44

45 2. Amount. The Performance Guarantee amount shall be based on a detailed  
46 estimate prepared by the applicant, broken down by unit cost and quantity, and

1 reviewed by the Town Engineer. Costs included in the estimate shall include,  
2 but not be limited to, completion of all roads, sewer, water, drainage, open  
3 space, landscaping, lighting and other required improvements shown on the  
4 approved plans. The cost estimate shall also include a contingency amount  
5 equal to ten (10) percent of the Performance Guarantee estimate.  
6

7 3. Phasing. When the Planning Board has approved phasing of a subdivision, a  
8 Performance Guarantee may be posted for one (1) or more phases. The amount,  
9 terms and conditions of the Performance Guarantee shall correspond with the  
10 phase or phases scheduled to be constructed. Construction activity shall only be  
11 located and permitted in phases for which a Performance Guarantee has been  
12 posted.  
13

14 4. Reductions and Release. All requests for reduction or release of the  
15 Performance Guarantee shall be submitted in writing to the Town Manager.  
16 Reduction requests should only be submitted after significant construction has  
17 been accomplished. Prior to approving a reduction or release of a Performance  
18 Guarantee, the Town Manager shall request a report from the Town Engineer  
19 confirming the quality and value of the construction completed. Any reduction  
20 or release shall preserve the Town's ability to require or complete construction  
21 that is consistent with the approved plans and the Town's construction standards  
22 and/or restore and stabilize the site if construction will not be continued. There  
23 shall be no final release of any Performance Guarantee until the record drawings  
24 have been received and approved by the Town Engineer.  
25

26 **(d) Inspection Fee.** In addition to the Performance Guarantee, the applicant shall pay an  
27 inspection fee. When the Performance Guarantee equals five hundred thousand  
28 dollars (\$500,000) or less, the inspection fee amount shall be five percent (5%) of the  
29 amount of the total performance guarantee. When the Performance Guarantee  
30 exceeds five hundred thousand dollars (\$500,000), the inspection fee amount shall be  
31 two and one-half percent (2.5%) of the cost of the total Performance Guarantee. The  
32 fee shall be payable by certified check to the Town of Cape Elizabeth. The inspection  
33 fee shall be held by the Town to defray the Town's cost for inspection by the Town  
34 Engineer and Town staff. Any funds not disbursed for this purpose shall be returned  
35 to the applicant upon release of the Performance Guarantee. If the costs for inspection  
36 exceed the amount of the inspection fee, the applicant shall pay an additional fee to  
37 the Town, which shall be recommended by the Town Engineer and approved by the  
38 Town Manager based on the status of the development.

### 39 **Sec. 16-2-7. Construction Administration**

40 **(a) Commencement of Construction.** At least ten (10) days prior to commencing  
41 construction of required improvements, the subdivider shall request a pre-  
42 construction meeting with the Town Manager. At the meeting, the subdivider shall  
43 submit plans for construction of the subdivision and notify the Town Manager when  
44 construction of such improvements will commence. The subdivider is also  
45 responsible for communicating ongoing progress of construction so that the Town can  
46 cause inspections and so that requirements shall be met during construction and to

1 assure satisfactory completion of all improvements and utilities required by the  
2 Planning Board. [Revised eff. 11/11/83; Revised eff. 6/13/90]

3  
4 **(b) Notice of Inspection.** To assure proper inspection of roads and other required  
5 improvements, the Town Engineer should be given not less than twenty-four (24)  
6 hour notice by the subdivider for inspections required at the following construction  
7 stages: (1) before backfilling of any surface water, sanitary sewer, domestic water or  
8 other underground lines or improvements, (2) at completion of road subgrades and  
9 after installation of gravel surface, (3) at the commencement of paving, loaming, or  
10 other final surface preparation, and (4) upon final completion.

11  
12 **(c) Inspection of Required Improvements.** All required subdivision improvements for  
13 which a Performance Guarantee are required shall be constructed under the  
14 observation of a qualified construction monitor. The qualifications of the construction  
15 monitor shall be subject to the review and approval of the Town. Construction  
16 monitoring costs shall be borne by the subdivider. The construction monitor shall be  
17 on the site during all periods of time when significant construction is taking place.  
18 Significant construction shall include (1) embankments, (2) bedding and backfilling  
19 of all underground utilities including water lines, unless the installation is supervised  
20 by the utility company, (3) installation of storm drainage and associated structures,  
21 (4) installation of sanitary sewers and associated structures, (5) roadway subbase  
22 material, (6) roadway base material, (7) paving, (8) compaction testing, and (9) sewer  
23 and manhole testing. The duties of the construction monitor shall also include (1)  
24 knowledge of product reports and material submittals, (2) maintenance of a diary of  
25 construction progress, and (3) implementation of remedial measures.

26 **(d) Authority of Town Engineer.** The Town Engineer shall have access to the site at all  
27 times to review the progress of the work and shall have the authority to review the  
28 field logs maintained by the construction monitor. Any deficiencies noted by the  
29 Town Engineer shall be brought to the attention of the construction monitor who shall  
30 see that remedial measures are taken.

31  
32 If the Town Engineer finds upon inspection of required improvements, including an  
33 inspection to be done by the Town Engineer before expiration of the Performance  
34 Guarantee, that any of such improvements are not constructed in accordance with  
35 plans and specifications filed by the subdivider, or that in the Town Engineer's  
36 judgment the applicant will be unable to complete the required improvement within  
37 the period specified in the Performance Guarantee, the Town Engineer shall then so  
38 notify the subdivider and the Town Manager, who shall take all necessary steps to  
39 preserve the rights of the Town under the Performance Guarantee, including  
40 authorization to the Town Engineer to stop the construction of said improvements.

41  
42 **(e) Field Changes.** If at any time before or during the construction of the required  
43 improvements the subdivider demonstrates to the satisfaction of the Town Engineer  
44 that unforeseen conditions make it desirable to modify the design of such  
45 improvements, the Town Engineer may, in consultation with the Public Works  
46 Director and Planner, authorize modifications provided that they are within the spirit



1 and intent of the Planning Board approval and do not constitute waiver or substantial  
2 alteration of the function of any improvements required by the Planning Board. The  
3 Town Engineer shall issue any authorization under this section in writing, and shall  
4 transmit a copy of such authorization to the Planner and Planning Board.  
5

6 **(f) Record drawings.** Upon completion of construction, the subdivider shall present to  
7 the Town one (1) set of reproducible mylar, one (1) hard copy, and one (1) electronic  
8 file of record drawings indicating facilities as constructed. The record drawings shall  
9 be based on the field logs of the construction monitor and of a quality acceptable to  
10 the Town. The record drawings shall include an engineer's seal, distances, angles and  
11 bearings for complete and accurate determinations of locations on the ground, right-  
12 of-way monuments and as set, as-built profiles of the centerlines of traveled ways,  
13 ledge elevations encountered during construction and information on the locations,  
14 size, materials and elevations of storm drains, sanitary sewers and other underground  
15 utility lines, including but not limited to water, electric, telephone, natural gas, cable  
16 television.

17 **(g) Completion and Acceptance.** Upon completion of the subdivision infrastructure, the  
18 subdivider may request that the Town Council accept proposed public improvements.  
19 The request shall include confirmation from the Town Manager that the  
20 improvements have been constructed consistent with the approved plans and town  
21 construction standards and that any applicable deeds have been submitted in a form  
22 acceptable to the Town Attorney and signed by the subdivider. The applicant shall be  
23 required to maintain all improvements and to provide for snow removal on roads and  
24 sidewalks, until their acceptance by the Town or the assumption of those  
25 responsibilities under such other approved arrangements.

## 26 **Article III. Standards**

27 **Sec. 16-3-1. Subdivision Review Standards.** A subdivision shall meet all of the  
28 following standards of review, as determined by the Planning Board.

### 29 **(a) Pollution**

30 The proposed subdivision will not result in undue water pollution. Factors to consider  
31 include:

- 32 1. The elevation of the land above sea level and its relation to the floodplains.
- 33 2. The nature of soils and subsoils and their ability to adequately support waste  
34 disposal.
- 35 3. The slope of the land and its effect on effluents.
- 36 4. The availability of streams for disposal of effluents.
- 37 5. The applicable state and local health and water resource rules and regulations.

### 38 **(b) Sufficient Potable Water**

39 The proposed subdivision has sufficient water available for the reasonably  
40 foreseeable needs of the subdivision. If a public water supply will be used, the

1 proposed subdivision will not cause an unreasonable burden on the existing public  
2 water supply.

3 **(c) Erosion**

4 The proposed subdivision will not cause unreasonable soil erosion or a reduction in  
5 the land's capacity to hold water so that a dangerous or unhealthy condition results.

6 **(d) Traffic**

7 1. Road congestion and safety. The proposed subdivision will not cause  
8 unreasonable highway or public road congestion or unsafe conditions with respect  
9 to the use of the highways or public roads existing or proposed, and if the  
10 proposed subdivision requires driveways or entrances onto a state or state aid  
11 highway located outside the urban compact area of an urban compact  
12 municipality as defined by Title 23, M.R.S.A. Section 745, the Department of  
13 Transportation has provided documentation indicating that the driveways or  
14 entrances conform to Title 23, M.R.S.A Section 704 and any rules adopted under  
15 that section.

16 2. Comprehensive Plan. The proposed subdivision road(s) shall conform to the  
17 Comprehensive Plan as adopted in whole or in part by the Town Council.

18  
19 3. Connectivity. The Planning Board may require provision for the projection of  
20 roads or for access to adjoining property, whether subdivided or not. The Planning  
21 Board shall require that access from the subdivision to previously existing or  
22 proposed public ways include two means of such vehicular access, as described in  
23 Sec. 16-3-2(5) of this Ordinance.

24  
25 4. Safety. All roads within a subdivision and roads providing access to a subdivision  
26 shall be designed so that they will provide safe vehicular and pedestrian travel and  
27 traffic patterns.

28  
29 5. Through traffic. The Planning Board may require that local roads be laid out so  
30 that their use by through traffic will be discouraged.

31  
32 6. Topography. Roads in the proposed subdivision shall be laid out in an attractive  
33 manner, in order to enhance the livability and amenity of the subdivision. Insofar  
34 as possible, roads shall conform to existing topography, and high cuts and fills  
35 shall be avoided.

36  
37 7. Block Length. Block lengths shall not exceed one thousand (1,000) feet except  
38 where a greater length suits the topography or character of the subdivision and  
39 does not result in an awkward road pattern or detrimental effect to adjacent  
40 property.

41  
42 8. Lot Access. Each property shall be provided with vehicular access to each lot by  
43 an abutting public or private road. A private road shall be protected by a

1 permanent easement which shall conform to the Road Classification Standards  
2 Table and which shall be shown on the plan.

- 3  
4 9. Sidewalks/pedestrian connections. The Planning Board may require sidewalks  
5 and/or curbing on either or both sides of any road, where they are or may be  
6 necessary for maintenance and/or public safety, as determined by the Planning  
7 Board.

8  
9 Provision of pedestrian easements or other types of pedestrian accessways not less  
10 than ten (10) feet wide may be recommended to the applicant, where a pedestrian  
11 accessway would add to the Town's Greenbelt System or where the Planning  
12 Board deems it important for pedestrian enjoyment or to provide access to but not  
13 limited to schools, playgrounds, shopping centers, recreation areas, open space,  
14 trails, shore frontage, and other facilities. Where feasible, the easements shall  
15 connect to existing and proposed recreation trails.

- 16  
17 10. Road Name. Road names shall not be used which will duplicate or may be  
18 confused with the names of existing roads. Road names shall be subject to the  
19 approval of the Planning Board and be in compliance with the Town of Cape  
20 Elizabeth Addressing Ordinance, Chapter 22, as determined by the Police Chief.

- 21  
22 11. Road Construction Standards. Proposed roads are designed in compliance with  
23 the Road Construction and Design Standards, Sec. 16-3-2.

24  
25 **(e) Sewage Disposal**

26  
27 The proposed subdivision will provide for adequate sewage disposal and will not  
28 cause an unreasonable burden on municipal services if they are utilized. All systems  
29 proposed for the disposal of sewage for developments regulated by this Ordinance  
30 shall be in compliance with the provisions of the Town of Cape Elizabeth Sewer  
31 Ordinance, Chapter 15.

32  
33 **(f) Solid Waste Disposal**

34  
35 The proposed subdivision will provide for adequate disposal of solid waste. The  
36 proposed subdivision will not cause an unreasonable burden on the municipality's  
37 ability to dispose of solid waste, if municipal services are to be utilized.

38  
39 **(g) Aesthetic, cultural and natural values**

40  
41 The proposed subdivision will not have an undue adverse effect on scenic or natural  
42 areas, aesthetics, historic sites, significant wildlife habitat identified by the  
43 Department of Inland Fisheries and Wildlife or the municipality, or rare and  
44 irreplaceable natural areas or any public rights for physical or visual access to the  
45 shoreline.

- 1       1. Scenic. Consideration shall be given by the applicant and the Planning Board to  
2       the impact of the proposed development on scenic vistas and view corridors to  
3       and from significant natural features, historic sites, and important topographic  
4       features as identified in the Town's Comprehensive Plan. The Planning Board  
5       may consider the impact of other design features such as building bulk,  
6       architectural style, building placement and landscaping to encourage visual  
7       harmony.  
8
- 9       2. Wildlife. The applicant shall make adequate provision for the protection of  
10       wildlife habitat and fisheries areas, which may include but are not limited to  
11       maintenance of wildlife travel lanes, and the preservation and buffering of  
12       wildlife habitat areas from proposed development activities.  
13
- 14       3. Natural features. The applicant, whenever practical, shall be required to preserve  
15       natural features such as water courses or bodies, existing trees of ten (10) inches  
16       or more in diameter (base height), open space, scenic points, historic spots, and  
17       unusual or striking topographic features which, if preserved, would add to the  
18       attractiveness of the subdivision.  
19
- 20       4. Farmland. All farmland within the proposed subdivision shall be identified on  
21       maps submitted as part of the application.  
22

23 **(h) Conformity with local ordinances**

- 24
- 25       1. Comprehensive Plan. The proposed subdivision is consistent with applicable  
26       provisions of the Comprehensive Plan.  
27
- 28       2. Zoning Ordinance. The area and width of lots shall conform to the requirements  
29       of the Zoning Ordinance. Side lot lines shall be substantially at right angles or  
30       radial to road lines.  
31
- 32       3. Multiplex Housing. Multiplex housing and cluster developments shall be so  
33       designed, sited and laid out as to minimize disturbance of existing topography and  
34       ground cover, provide maximum usable natural or improved open space, reflect  
35       imaginative use of the site, and be compatible with any surrounding land uses and  
36       their character. The minimum lot size and density requirements for any proposed  
37       multiplex housing or cluster development shall comply with the Zoning  
38       Ordinance.  
39
- 40       4. Addressing Ordinance. The street numbering of the individual residential  
41       dwelling units and/or lots must be clearly visible on the plans and shall be done in  
42       compliance with the Town of Cape Elizabeth Addressing Ordinance, Chapter 22.  
43       For any development with more than one set of attached or multiplex dwelling  
44       units, signs clearly identifying the house numbers in each set of dwelling units  
45       shall be required to be placed along the road leading to each set of units and shall  
46       be subject to approval of the Fire Chief and Police Chief.

1  
2 **(i) Financial and Technical Capability**  
3

4 The applicant shall demonstrate adequate technical and financial capability to  
5 complete the project as proposed. In the case where the applicant asserts that public  
6 disclosure of confidential financial information may prove detrimental to the  
7 applicant or to the success of the subdivision, the Town Manager may review the  
8 financial records of the applicant and recommend to the Planning Board that financial  
9 capability is adequate.  
10

11 **(j) Surface Waters**  
12

13 Whenever situated entirely or partially within the watershed of any pond or lake or  
14 within two hundred fifty (250) feet of any wetland, great pond or river as defined in  
15 Title 38 M.R.S.A. Chapter 3, subchapter I, article 2-B, the proposed subdivision will  
16 not adversely affect the quality of that body of water or unreasonably affect the  
17 shoreline of that body of water. The Planning Board may determine that the proposed  
18 subdivision will not adversely affect surface water quality if the subdivision has been  
19 designed to comply with the Shoreland Performance Overlay District.  
20

21 **(k) Ground Water**  
22

23 The proposed subdivision will not, alone or in conjunction with existing activities,  
24 adversely affect the quality or quantity of ground water.  
25

26 **(l) Flood Areas**  
27

28 The Planning Board shall review all subdivision proposals to assure that: (1) they are  
29 designed to minimize flood damage; (2) all public utilities and facilities, such as  
30 sewer, gas, electrical, and water systems are located, elevated, and constructed to  
31 minimize or eliminate flood damage; (3) adequate drainage is provided so as to  
32 reduce exposure to flood hazards; and (4) the proposed subdivision otherwise meets  
33 the standards of the Town of Cape Elizabeth Construction Code, Chapter 6,  
34 Floodplain Regulations.  
35

36 **(m) Wetlands**  
37

38 Any proposed alteration of wetlands shall adhere to the requirements and standards of  
39 Section 19-6-9 and Section 19-8-3 of the Zoning Ordinance.  
40

41 **(n) Stormwater**  
42

43 The proposed subdivision will provide for adequate stormwater management.  
44

45 For any subdivision involving more than ten thousand (10,000) square feet of  
46 impervious surface, paving, clearing or vegetative alteration, the provisions and

1 improvements for the control of storm water runoff shall be governed by the  
2 provisions of the Town of Cape Elizabeth Storm Water and Non-Storm Water  
3 Control Ordinance Chapter 18, Article II and Post Construction Stormwater  
4 Management Ordinance, Chapter 18, Article IV. In the case of any subdivision  
5 involving less than ten thousand (10,000) square feet of such impervious surfaces,  
6 where a subdivision is traversed by a stream, drainage way or other watercourse, or  
7 where the Planning Board with the advice of the engineer feels that surface water  
8 drainage to be created by the subdivision should be controlled for the protection of  
9 the subdivision and owners of property abutting it, there shall be provided an  
10 easement or drainage right-of way conforming substantially with the lines of such  
11 watercourse, and culverts, catch basins or other means of channeling surface water  
12 within such subdivision and over the property of owner abutting upon it of such  
13 nature, width and location as the Planning Board with the advice of the Town  
14 Engineer, deems adequate.

15  
16 **(o) Lake Phosphorus concentration**

17  
18 The long term cumulative effects of the proposed subdivision will not unreasonably  
19 increase a great pond's phosphorus concentration during the construction phase and  
20 life of the proposed subdivision. The Planning Board may consider compliance with  
21 the Great Pond Watershed Overlay District, Sec. 19-6-12, Zoning Ordinance, as  
22 demonstration of no unreasonable increase.

23  
24 **(p) Impact on adjoining municipality**

25  
26 For any proposed subdivision that crosses municipal boundaries, the proposed  
27 subdivision will not cause unreasonable traffic congestion or unsafe conditions with  
28 respect to the use of existing public ways in an adjoining municipality in which part  
29 of the subdivision is located.

30  
31 **(q) Land subject to Liquidation Harvesting**

32  
33 The proposed subdivision is not located on land where timber has been harvested in  
34 violation of rules adopted pursuant to Title 12 M.R.S.A. Section 8869, subsection 14  
35 or the violation occurred at least five (5) years before the subdivision application has  
36 been submitted.

37  
38 **(r) Access to Direct Sunlight**

39  
40 Consideration shall be given by the applicant and the Planning Board to the  
41 sensitivity of the proposed subdivision design for the purpose of protecting and  
42 assuring access to direct sunlight. The Planning Board may, to protect and ensure  
43 access to direct sunlight for solar energy systems, prohibit, restrict, or control  
44 development through methods such as but not limited to restrictive covenants, height  
45 restrictions, and side yard and setback requirements.

1 (s) **Buffering**

2  
3 Plants or other types of vegetative cover shall be preserved or placed throughout and  
4 around the perimeter of any proposed subdivision to provide for an adequate buffer,  
5 reduction of noise and lights, separation between the subdivision abutting properties,  
6 and enhancement of its appearance.  
7

8 Off-road parking lots, storage areas, rubbish disposal areas, or similar improvements  
9 exposed to public roads or to residential areas shall be screened by walls, earth berms,  
10 fences, or vegetation, and shall be properly landscaped.  
11

12 (t) **Open Space Impact Fee**

- 13  
14 1. Purpose. In order to accommodate the expected needs of the subdivision for open  
15 space and recreational areas without diminishing the community standard of  
16 public open space, the applicant shall be required to donate land with legal public  
17 access or otherwise conserved with a public benefit or a cash contribution in lieu  
18 of actual land dedication, or a combination of the above, at the option of the  
19 Planning Board and with the advice of the Conservation Commission.  
20  
21 2. Community Standard. Public open space shall include the inventory of open space  
22 for which there is legal public access, including:  
23  
24 i. Open space owned by the Town;  
25 ii. Open space encumbered by an easement owned by the Town which allows  
26 public access;  
27 iii. Open space owned by the Cape Elizabeth Land Trust; and  
28 iv. Open space encumbered by an easement owned by the Cape Elizabeth Land  
29 Trust which allows public access. The Community Standard of public open  
30 space shall be defined as the total acreage of open space divided by the  
31 Town's population, as of the most recent U.S. Census.  
32  
33 3. Land donation. The required land donation of open space shall be calculated by  
34 multiplying the number of lots/units in the proposed subdivision by the average  
35 number of persons per household as published in the most recent U.S. Census,  
36 and then multiplying the resulting number by the Community Standard of public  
37 open space. At least twenty percent (20%) of the land donated shall be land which  
38 is not a Resource Protection Zone or buffer and has a slope not to exceed fifteen  
39 percent (15%).  
40  
41 4. Fee. If the resulting land dedication would be too small to be useful, or  
42 inappropriately located, the Planning Board may require the applicant to pay a fee  
43 in lieu of all or part of the required land dedication. The fee shall be calculated by  
44 multiplying the amount of acreage which otherwise would have been required to  
45 be donated with the proposed subdivision (rounded to the nearest one-hundredth  
46 of an acre) by the average fair market value of one acre of vacant land (rounded to

1 the nearest dollar) determined by the Town Assessor using accepted professional  
2 valuation methods.

- 3
- 4 5. Administration. The type of land donated and land conveyance by fee ownership  
5 deed or easement shall be consistent with the land included in the town inventory.  
6 Open space impact fees shall be segregated from the Town's general revenues and  
7 expended only for the acquisition or improvement of public open space. The  
8 Town shall refund to the applicant that portion of the collected open space impact  
9 fee that is not expended within ten (10) years from the date of receipt. The  
10 Community Standard of public open space, average fair market value of one (1)  
11 acre of vacant land, and open space impact fee therein derived shall be published  
12 in the Fee Schedule approved and periodically updated by the Town Council. The  
13 Fee Schedule shall be available for inspection at the office of the Town Clerk.  
14 Any required fee shall be paid prior to the commencement of construction of the  
15 subdivision and/or issuance of a building permit.

16

17 **(u) Utility Access.**

18

19 All lots shall have access to water, electrical, and telephone and other utilities.

20

21 **(v) Phasing.**

22

23 If a subdivision is proposed for development in phases, no portion of the subdivision  
24 may be left out of the phasing plan. Sequence of construction of subdivision phases  
25 shall be determined. Each phase or, as applicable, sequence of phases shall preserve  
26 the standards of review of Sec. 16-3-1 of this Ordinance, with emphasis on  
27 emergency vehicle access. The Planning Board may impose such conditions as it  
28 deems necessary to assure the orderly development of the subdivision to assure that  
29 all necessary improvements are made for each separate phase.

30

31 **Sec. 16-3-2. Road Design and Construction Standards** The purposes of the subdivision  
32 road standards are to minimize traffic safety hazards and the cost of municipal  
33 maintenance and reconstruction, to ensure that roads are consistent with the Town's rural  
34 character, to promote a sense of community, and to be consistent with the Comprehensive  
35 Plan. The standards shall be flexible where an applicant can demonstrate that alternative  
36 approaches will meet the above stated purposes. Roads within a subdivision shall be  
37 classified by the Planning Board in accordance with their location and their present and  
38 contemplated usage. A road which is likely to be upgraded in classification in the  
39 foreseeable future shall be laid out to the standards of the potential future classification.  
40 The widths and grades for all subdivision roads shall be determined in accordance with  
41 the **Road Classification Standards Table**, subject to the following qualifications:

- 42
- 43 1. Where an existing road with right-of-way of less than fifty (50) feet is being  
44 extended, the new right-of-way may be the same width as the existing road upon  
45 approval by the Planning Board and Public Works Director.



- 1 2. Width of right-of-way may be forty (40) feet for a road shorter than three-hundred  
2 (300) feet which ends in a cul-de-sac, upon approval by the Planning Board and  
3 Town Engineer.  
4  
5 3. Notwithstanding the **Road Classification Standards Table**, dead-end roads in excess  
6 of one thousand (1,000) feet in length must comply with Sec. 16-3-2 (a)(9) of this  
7 Ordinance.  
8

9 **A. Road Design**

10 1. Sight Distance

11  
12 **a. New Subdivision Road sight distance.**

13  
14 (1) Measurement. Sight distance shall be measured from a height 3.5 (three  
15 and one half) feet above the traveled way, in each direction of the road to a  
16 height .5 (one-half) foot above the pavement.

17 (2) Standard. The road shall be designed to achieve a sight distance in the  
18 range indicated on the **Road Classification Standards Table**. The maximum  
19 sight distance range shall not be exceeded without reasonable justification  
20 which shall be presented by the applicant.  
21

22 **b. Road Intersections.**

23  
24 (1) Measurement. The sight distance for a road entering onto a second road  
25 shall be measured from a location fifteen (15) feet behind the edge of traveled  
26 way of the side road or drive at an elevation of three and one half (3.5) feet  
27 above the finished grade surface to a point four and one quarter (4.25) feet  
28 above the pavement in the centerline of the travel lane approaching the  
29 intersection. Where unavoidable obstructions are encountered at the fifteen  
30 (15) foot setback, the location may be moved to a point no closer than ten (10)  
31 feet from the traveled way. Isolated interruptions of minimal time duration in  
32 sight distance due to obstructions, such as a single tree, shall not be included  
33 in the measurement of sight distance.  
34

35 (2) Standard. The road intersection shall be designed to achieve a sight  
36 distance in the range indicated on the **Road Classification Standards Table**.  
37

38 **c. Single Family driveways.** When the Planning Board requires that an  
39 individual driveway be shown on the subdivision plan, the sight distance  
40 measurement and standard shall meet the requirements in the **Road**  
41 **Classification Standards Table**.  
42

43 2. Road Geometry. New subdivision roads shall be designed to comply with the  
44 **Road Classification Standards Table** and the following standards:  
45

1  
2  
3  
4  
5  
6  
7  
8  
9  
10  
11  
12  
13  
14  
15  
16  
17  
18  
19  
20  
21  
22  
23  
24  
25  
26  
27  
28  
29  
30  
31  
32  
33  
34  
35  
36  
37  
38  
39  
40  
41  
42  
43  
44  
45  
46

- a. **Horizontal Alignment.** At all changes in alignment, road sidelines shall be connected by horizontal curves. All changes in slope shall be connected with vertical curves whose length shall be consistent with the **Road Classification Standards Table**. When the degree of curvature exceeds two (2) degrees on rural connector, collector, or arterial roads, the curves shall be super-elevated to meet the criteria established by AASHTO, most current edition.
  
  - b. **Intersection Design**
    - (1) Roadway grades approaching an intersection shall not exceed three (3) percent for a distance of fifty (50) feet from the edge of paving of the road being entered.
  
    - (2) Road intersections shall be separated at least one hundred twenty-five (125) feet whenever possible. A separation of less than one hundred twenty-five (125) feet may be acceptable when a low volume of traffic allows for safe traffic circulation.
  
    - (3) At intersections and common boundaries of subdivisions, roads shall be continuous and in alignment with existing roads if possible. Roads shall be laid out so as to intersect as nearly as possible at right angles, and no road shall intersect any other road at less than a sixty (60) degree angle.
  
  - c. **Traveled Way.** The traveled way shall be designed consistent with the **Road Classification Standards Table**. Every traveled way shall maintain a constant width and shall be centered in its right-of-way. The Planning Board may also shift the traveled way up to five (5) feet from the center to preserve existing mature trees or minimize wetland alterations.
  
  - d. **Radii.** Radii of curves and lengths of tangents between curves shall be consistent with the **Road Classification Standards Table**. At a minimum, road radii shall provide adequate turning radius for a B-40 vehicle as defined by AASHTO. To measure turning radius, the full width of pavement of both lanes of traffic shall be included, exclusive of shoulder areas. Minimum turning radius shall be required from both directions of the intersecting road.
  
  - e. **Shoulders.** The width of shoulders and surfacing shall be determined by reference to the **Road Classification Standards Table**. The road lanes shall be striped to provide a traveled way in compliance with the **Road Classification Standards Table**.
3. **Sidewalks.** Sidewalks shall be five (5) feet wide and shall be separated from the traveled way by a grassed esplanade in accordance with the **Road Classification Standards Table**. When locating the sidewalk, a one (1) foot wide buffer strip shall be preserved along the right-of-way between the back edge of the sidewalk

1 and the right-of-way. Sidewalks shall be required on one side of the road and  
2 notwithstanding Sec. 16-3-5 of this Ordinance, shall not be waived by the  
3 Planning Board. The design of a Rural Connector shall include a sidewalk path  
4 within ten (10) feet of the outside edge of the right-of-way. The sidewalk path  
5 shall be field located to avoid significant vegetation.  
6

7 4. Curbing.  
8

9 **a. Installation.** Curbing shall be installed at road intersections and have a radius  
10 of at least twenty-five (25) feet, unless otherwise approved by the Town  
11 Engineer. Curbing may be required to aid in slope stabilization.  
12

13 **b. Material.** Curbing shall consist of granite, extruded concrete or bituminous  
14 concrete; design and choice of materials for curbing shall be based upon the  
15 anticipated use of the road involved and shall be subject to the approval of the  
16 Town Engineer and the Public Works Director. Granite curbing specifications  
17 shall be five inch by seventeen (5 x 17) inch vertical plus or minus one (1)  
18 inch vertical as required by the Public Works Director. Granite curbing  
19 installed at intersection shall be set in concrete.  
20

21 5. Drainage. All roads shall have an underground enclosed drainage system, and no  
22 surface drainage shall be conveyed or diverted across a traveled way.  
23

24 6. Road Signs. Road signs shall be approved by the Public Works Director and  
25 installed in compliance with MUTCD (Manual on Uniform Traffic Control  
26 Device) standards .  
27

28 7. Road Trees.  
29

30 **a. Adjacent to Road.** Each road shall be designed to include, within the right-  
31 of-way, at least one (1) tree for every forty (40) feet of road frontage but not  
32 less than two (2) trees per lot. All trees shall comply with tree species and size  
33 standards approved by the Town Tree Warden. Existing trees within the right-  
34 of-way which have been preserved may be counted toward this requirement if  
35 the species, size, preservation measures, and post-construction condition of  
36 the trees are approved by the Tree Warden. Where an esplanade is included in  
37 the road design, road trees required on that side of the street shall be planted in  
38 the esplanade. The esplanade shall be filled with soil, such as common  
39 borrow, suitable for growing trees. See also Appendix C, Road Tree List.  
40

41 **b. Cul-de-sac.** Landscaping including trees and other plant materials shall be  
42 required in the center island of a cul-de-sac.  
43  
44  
45  
46

1  
2  
3  
4  
5  
6  
7  
8  
9  
10  
11  
12  
13  
14  
15  
16  
17  
18  
19  
20  
21  
22  
23  
24  
25  
26  
27  
28  
29  
30  
31  
32  
33  
34  
35  
36  
37  
38  
39  
40  
41  
42  
43  
44  
45  
46

8. Dead-End Roads.

- a. **Length.** Dead-end roads shall not be longer than two thousand (2,000) feet in length and shall not serve more than twenty (20) dwelling units. The maximum length, the maximum number of dwelling units and the mandatory requirements of dead-end roads shall not be waived by the Planning Board, notwithstanding the waiver provision in Sec. 16-3-5 of this Ordinance.
- b. **Minimum Requirements.** Any dead-end road in excess of one thousand (1,000) feet in length shall meet mandatory requirements for the entire length of the dead-end road. Mandatory requirements shall include (1) the placement of all utilities underground, (2) the dedication to the Town of a fifty (50)foot wide right-of-way, and (3) a minimum pavement width of twenty-two (22) feet.
- c. **Added Requirements.** The Planning Board may require improvements such as (1) the placement of sidewalks to Town specifications, (2) limited clearing of the right of-way with the advice of the Town Tree Warden on the stability of adjacent tree growth, (3) the provision of an emergency access lane with a minimum width of eighteen (18) feet and (4) a minimum esplanade width of six (6) feet for divided entrances.
- d. **Measurement.** A dead-end road shall be measured from the end of the existing or proposed dead-end road to the closest intersecting through road. The measurement shall include proposed road(s) and existing road(s), public or private, whether within or beyond the limits of the proposed subdivision. The length of the road shall be measured from the center line of the closest through road, along the center line of the dead-end road to the end of pavement or traveled way. Divided entrances shall be allowed only if they provide direct access to arterial roads as classified by the Town.
- e. **Termination.** All dead-end roads shall end in a cul-de-sac or a T-shaped turnaround and be designed according to the dimensions shown on Appendix D. All cul-de-sacs shall be so designed that water will drain from all portions into a storm water drainage system. The interior of all cul-de-sacs shall be neat and orderly, and shall either be left in its natural condition or be graded, loamed and seeded. Granite monuments shall be installed by the developer at the intersection of each side of the road with the cul-de-sac and at the radius point of the cul-de-sac, as shown in the cul-de-sac diagrams.

A T or L-shaped turnaround may be used and placed on the right side of the road. All T-shaped turnarounds, whether temporary or permanent, shall be paved. No parking is allowed in a turnaround. See also Appendix D, Turnaround Design.

9. Private Road. The first fifty (50) feet of a private road from the edge of the road shall be paved. A private road shall be constructed in accordance with the right-

1 of-way width, gravel base, traveled way width and monumentation of a local  
2 road. The Planning Board may require that a road be constructed to public road  
3 standards; further the Planning Board shall require dedication of the roads as  
4 public rights-of-way if there is potential for future development that could be  
5 accessed through the proposed subdivision.  
6

- 7 10. Monuments. A four (4) inch square granite monument shall be set at each point  
8 of curvature and angle point on both sides of every road and at every property line  
9 intersection. A surveyor's pin shall be set at each property line corner. Except  
10 with the permission of Public Works Director, all monumentation shall set flush  
11 with existing grade. At road intersections and at locations where monuments on  
12 one road line would fall within two hundred (200) feet of each other, the Public  
13 Works Director may reduce this requirement provided that the reduced  
14 monumentation is adequate for road line surveys. (Revised eff. 12/10/03)  
15

16 **B Road Construction**

17 1. Clearing

- 18  
19 a. Prior to site alteration, a land surveyor registered in the State of Maine shall  
20 mark the layout of the road and verify for the Town Engineer that the layout is  
21 in conformance with the approved plans.  
22  
23 b. The construction area shall be selectively cleared of all trees, brush and  
24 vegetation only as necessary for construction of the roadway, shoulder,  
25 utilities and any drainage ways as approved by the Planning Board. Clearing  
26 provisions shall be accomplished in accordance with the most recent revision  
27 of the Standard Specifications of the Maine Department of Transportation,  
28 Section 201.  
29  
30 c. Limits of clearing shall be marked in the field and may be inspected by the  
31 Town Engineer prior to further site preparation. In a Rural Connector, a ten  
32 (10) foot wide strip shall be preserved at the edge of the right-of-way, where a  
33 sidewalk path may be placed. The ten (10) foot wide strip shall be retained in  
34 a natural state and serve as a buffer, although trimming may be allowed to  
35 preserve scenic views.  
36

37 2. Grading to Subgrade

38  
39 The roadway shall be brought to subgrade through the process of excavation  
40 and/or placement of fill. Such earthwork shall be accomplished in compliance  
41 with the technical provisions of Section 203 of said MDOT Specifications.  
42 Blasted ledge, which is, less than fourteen (14) inches in any dimension, may be  
43 used as fill up to a level one foot and one-half (1.5) feet below subgrade, and  
44 shall be mixed with sufficient finer material to make a firm, stable embankment.  
45 Revised eff. 12/10/03)  
46

1           3. Base Gravel for Roadways & Sidewalks

2  
3           **a. Base Course.** The gravel base course shall be a minimum of one and one-half  
4           (1.5) feet in depth. When subgrade materials are marginal, the Town Engineer  
5           may require additional base gravel. The lower one (1) foot of material shall  
6           conform to the requirement of Section 703.06 (b). Types D or E of the said  
7           MDOT Specifications, except that no particle of rock shall exceed three (3)  
8           inches as determined by a three (3) inch square mesh sieve.

9  
10           **b. Upper Course.** The upper six (6) inches of material shall conform to the  
11           requirements of Section 703.06 (a). Types A and B of said MDOT  
12           Specifications except that maximum particle size for Type B shall be three (3)  
13           inches.

14  
15           **c. Compaction.** The base gravel shall be placed and compacted in accordance  
16           with technical requirements of Section 304 of said MDOT Specifications.  
17           Initial compaction tests shall be taken at a minimum interval of every fifty  
18           (50) linear feet along the roadway for each lift of material placed, and then  
19           compaction tests at a greater separation if initial tests pass. Retesting of any  
20           failed areas must be conducted after remedial action has been accomplished.  
21           Additional compaction tests may be required by the Public Works Director.

22  
23           **d. Sidewalk.** Gravel for sidewalk base shall be eight (8) inches in depth and shall  
24           meet the requirements of Section 703.06 (a) of said MDOT specifications,  
25           Types A,B, or D, placed in one lift compacted to ninety-five (95) percent of  
26           optimum density.

27  
28           **e. Esplanade.** The base of the esplanade located between the road and the  
29           sidewalk shall not be filled with gravel. The underlying material under the  
30           loam layer shall be common borrow or a similar material conducive to tree  
31           growth. The maximum grade of the esplanade cross-slope shall be two (2)  
32           percent.

33  
34           4. Paving.

35  
36           **a. HMA.** Paving shall be of Hot Mix Asphalt (HMA) meeting the requirements  
37           of Section 401 and 403 of said MDOT Specifications. Placement of HMA  
38           shall conform to MDOT Specifications (Section 401). Sidewalk HMA shall be  
39           placed in two (2) one and one quarter (1.25) inch lifts using 9.5 mm mix.  
40           HMA thickness shall be as follows:

	<b>Base Course 19 mm Mix unless otherwise noted</b>	<b>Surface Course 12.5 mm Mix, except local roads which shall be 9.5 mm</b>	<b>Surface Course 9.5 mm fine Mix</b>	<b>Total</b>
Arterial	2.5 inches	1.5 inches"	--	4 inches
Collector	2.5 inches	1.5 inches	--	4 inches
Rural Connector	2.5 inches	1.5 inches	--	4 inches
Feeder	2.5 inches	1.5 inches	--	4 inches
Local Roads	2.5 inches of 19 mm	1.5 inches	--	4 inches
Sidewalks	--	--	2.5 inches	2.5 inches

1  
2  
3  
4  
5  
6  
7  
8  
9  
10  
11  
12  
13  
14  
15  
16  
17  
18  
19  
20  
21  
22  
23  
24  
25  
26  
27  
28  
29  
30  
31  
32  
33  
34

- b. Base Course.** The HMA base course shall be 19 mm mix for all classes of roads, except local roads and sidewalks which shall be 9.5 mm mix as defined in Section 703.09 of said MDOT Specifications. Sidewalk paving shall be 9.5 mm (fine) mix.
- c. Placement.** Placement of all HMA shall be in compliance with the technical requirements of Section 401 of said MDOT Specifications.
- d. Driveways.** Driveway entrances shall include a paved apron starting at the edge of road pavement and extending four (4) feet toward the property being served. In locations where driveways are coincident with sidewalks, the paved apron shall extend from the edge of the road pavement to four (4) feet beyond the back of the sidewalk. Driveway aprons shall meet the criteria for local road paving.
- e. Curb Platform.** Where bituminous or extruded concrete curbing is to be placed, the paving shall extend one (1) foot beyond the back of curb to serve as a curb platform.

- 5. Curbing. Curbing shall be placed in accordance with Section 609 of said MDOT Specifications. Bituminous concrete curbing shall meet the requirements of Section 712.36 of said MDOT Specifications. Extruded concrete curbing shall meet the requirements of Section 712.03 of said MDOT specifications. The curb cross section shall be of the low profile berm curb type and shall be placed on top of the HMA base course.
- 6. Stone Fill, Riprap, Stone Ditch Protection. When required for erosion control, stone fill, riprap and stone ditch protection shall be placed in accordance with Section 610 of said MDOT Specifications.
- 7. Sodding - Erosion Control Mesh. Where required to prevent erosion and when indicated on the plans, sod shall be placed in accordance with the technical requirements of Section 616 of said MDOT Specifications. When required to

1 prevent erosion and where indicated on the plans, erosion control mesh shall be  
 2 placed in accordance with the technical requirements of Section 613 of said  
 3 MDOT Specifications.

- 4  
 5 8. Seeding. All exposed slopes and areas not to be paved shall be seeded in  
 6 accordance with the technical requirements of Section 618 of said MDOT  
 7 Specifications. Seeding Method 1 shall be used. Mulch shall be applied to all  
 8 seeded surfaces in accordance with the technical requirements of Section 619 of  
 9 said MDOT Specifications.

10  
 11 **Road Classification Standards Table**

12

	Right of Way	Traveled Way	Minimum Intersection Sight Distance	Width Shoulder	Horizontal Sight Distance	Design Speed	Sidewalk	Esplanade	Center Line Radius
ARTERIAL	52'	24'	200'	5'	200-400	30-45	5' (1)	5'	300-800
COLLECTOR	50'	24'	200'	1'	200-250	30-35	5' (1)	6'	300-400
RURAL CONNECTOR	66'	24'	200'	4'	200-250	30-35	5'	7'	300-400
FEEDER	50'	24'	150'	0'	150-200	25-30	5'	7'	150-300
LOCAL	50'	22'	125'	0'	125-150	20-25	5'	8'	125-150

(1) Either sidewalk or bikeway. Width should increase for dual purpose

13  
 14 See also Appendix E, Road Profiles

15  
 16 **Sec. 16-3-3. Design of Other Improvements**

17 **A. Storm and Surface Water Drainage**

- 18 1. Storm water collection and transport systems shall comply with the Town of Cape  
 19 Elizabeth Stormwater and Non-Stormwater Control Ordinance, Chapter 18,  
 20 Article II and the Town of Cape Elizabeth Post Construction Stormwater  
 21 Management Ordinance, Chapter 18, Article IV.  
 22



- 1 2. Ditches, where permitted, on the approved plans shall have a slope of at least two  
2 (2) percent and side slopes not exceeding three to one (3:1). Where required to  
3 prevent erosion, ditches shall be riprapped, sodded, or otherwise protected.  
4
- 5 3. Storm drain pipelines and culverts shall be installed in accordance with the  
6 technical requirements of Section 603 of said MDOT Specifications. All pipes  
7 shall be designed to withstand earth backfill plus H-20 wheel loadings. Trench  
8 backfill over drain lines within the paved way shall be compacted to ninety-five  
9 (95) percent of optimum density. Outside of paved areas backfill shall be  
10 compacted to ninety (90) percent of optimum density.  
11
- 12 4. When required to assure a stable subbase, rigid perforated underdrain pipe shall  
13 be installed in accordance with the technical requirements of Section 605 of said  
14 MDOT Specifications. Coiled underdrain pipe will not be permitted. (Revised eff.  
15 12/10/03)  
16
- 17 5. Manholes and catch basins on storm drain lines shall meet the technical  
18 requirements of Section 604 of said MDOT Specifications. Shop drawings for the  
19 units desired for use shall be submitted to the Town Engineer for approval prior to  
20 placement.  
21

## 22 **B. Underground Utility Lines**

- 23 1. All sanitary sewer lines and appurtenances shall be constructed in accordance  
24 with the requirements of the Town of Cape Elizabeth Sewer Ordinance,  
25 particularly Sec. 15-1-6 and 15-1-7.  
26
- 27 2. Any road to be accepted shall be served by a water main if said road joins a road  
28 containing a water main. No water main shall be less than eight (8) inches in  
29 diameter unless the fire department and the Planning Board certify in writing that  
30 a water main less than eight (8) inches in diameter will furnish adequate water  
31 service for the road to be accepted and for any future extension of said road.  
32
- 33 3. All underground utility mains shall be installed before the gravel surface is  
34 placed; and, if possible utility service lines to individual lots shall be installed  
35 before gravel surface is placed.  
36
- 37 4. Backfill materials for all underground utilities shall be compacted to ninety-five  
38 (95) percent of optimum density under paved areas and to ninety (90) percent of  
39 optimum density under non-paved areas.  
40

### 41 **Sec. 16-3-4. Additional Standards**

42 **(a) Right-of-Way.** The Planning Board with the advice of the Town Engineer may  
43 require rights-of-way wider than those set forth in the **Road Classification**  
44 **Standards Table**, in order to satisfy the purposes of this Ordinance.  
45

46 **(b) Reserved**

1  
2 (c) **Sewers** . Upon the advice of the Town Engineer, the Town Council may require an  
3 applicant to construct storm or sanitary sewers at a greater depth or of larger diameter  
4 than is required to serve the area being subdivided, when said greater depth or larger  
5 diameter is deemed necessary to provide proper service for adjacent areas.  
6

7 **Sec. 16-3-5. Waivers.** Where the Planning Board finds that undue hardship, practical  
8 difficulties or restriction upon imaginative and otherwise desirable design may result  
9 from strict compliance with this Ordinance, it may waive one or more of the requirements  
10 of this Ordinance, in favor of a proposed alternative upon a showing that, as compared  
11 with strict compliance, such alternative (1) will not create more hazardous traffic  
12 conditions or less sanitary sewage disposal conditions than strict compliance, (2) will  
13 provide more varied and imaginative subdivision layout and design, (3) will secure  
14 substantially the standards of road design and construction required by this Chapter and  
15 the Zoning Ordinance, and (4) will not have the effect of nullifying the intent and  
16 objectives of the Comprehensive Plan or this Ordinance; provided that in granting such  
17 waiver the Planning Board may impose such conditions as they deem necessary to secure  
18 the foregoing objectives.

19 **Sec. 16-3-6. Legal Provisions**

20 (a) **Appeals.** All appeals from decisions of the Planning Board under this Ordinance and  
21 the Zoning Ordinance shall be taken within thirty (30) days following the date of any  
22 such decision in accordance with the provisions of Rule 80B of the Maine Rules of  
23 Civil Procedure. This procedure shall apply whether or not the appeal involves issues  
24 requiring an interpretation of the Zoning Ordinance.  
25

26 (b) **Applicability of Road Requirements.** The provisions of this Ordinance shall serve as  
27 a guide to, but shall not be binding upon, any state, county or municipal body or  
28 authority, which may lay out, alter, widen or improve any public way in accordance  
29 with the applicable statutes. This Ordinance shall not apply to any roads within the  
30 Town for which road profiles had been approved by the Town Engineer prior to  
31 March 13, 1968, which were under actual construction as of March 12, 1968 and  
32 which had been completed not later than October 14, 1968.  
33

34 (c) **Amendments to the Subdivision Ordinance.** This Ordinance may be amended by  
35 the Town Council following the procedure outlined in Sec. 19-4-9 of the Zoning  
36 Ordinance.  
37

38 (d) **Historical Interpretation.** This Ordinance replaces the Subdivision Ordinance as  
39 amended through 12-10-2003. Most of the prior ordinance provisions have not been  
40 substantively changed and have been brought forward into this Ordinance. When that  
41 is the case, the interpretation by the Town of the provision in the prior ordinance is  
42 carried forward to this Ordinance.  
43  
44  
45  
46

1 **Appendix A**

2 **Minor Subdivision Submission Requirements**

3 A. General submission parameters.

4 An application for a Minor Subdivision shall consist of fourteen (14) sets of plans drawn  
5 to a scale of no larger than forty (40) feet to the inch and supporting materials. The size  
6 of plan sheets submitted to the Planning Board shall be no larger than twenty-four (24) x  
7 thirty-six (36) inches, but may be smaller with the permission of the Planning Board. A  
8 digital copy of the complete application shall also be made available upon request.

9 B. List of Submission items.

10 The application for approval of a Minor Subdivision shall include all the following  
11 information. Information that must be shown on a plan is in **bold type**.

- 12 1. Right, Title or Interest. Evidence of right, title or interest in the site of the proposed  
13 subdivision.
- 14
- 15 2. Name of Subdivision/Applicant. **Proposed name of the subdivision, name and**  
16 **address of record owner and applicant, names of adjoining property owners,**  
17 **date of submission, north point, and graphic map scale.**
- 18
- 19 3. Survey. **A standard boundary survey of the site, giving complete descriptive data**  
20 **by bearings and distances, made and certified by a licensed land surveyor;** a  
21 copy of the deed for the property to be developed, as well as copies of any easements,  
22 restrictions or covenants; **a plan showing the number of the lot, dimensions of area**  
23 **and building envelope of each proposed lot; existing easements; building lines**  
24 **pertaining to the proposed subdivision and to the adjacent properties; location**  
25 **map, showing the relative location of the proposed project in relation to**  
26 **surrounding neighborhoods or areas of Town; sufficient data to determine**  
27 **readily the location, bearing and length of every lot line, and boundary line and**  
28 **to reproduce such lines upon the ground.** Where practical these should be tied to  
29 reference points previously established
- 30
- 31 4. Water Pollution evaluation.
- 32
- 33 a. Topography. **Contour lines at intervals of two (2) feet or at such intervals as**  
34 **the Planning Board may require, based on United States Geological Survey**  
35 **datum, referenced to mean sea level;**
- 36
- 37 b. Surface drainage. **Surface drainage patterns including drainage channels and**  
38 **watershed areas;** the slope of the land and its effect on effluents; the availability  
39 and condition of streams used for disposal of effluents; an evaluation of  
40 applicable state and local health and water resource rules and regulations.
- 41
- 42 c. Soils. A soils report identifying **the soils boundaries and names in the proposed**  
43 **development with the soils information superimposed upon the plot plan in**

- 1           **accordance with the USDA Soil Conservation Service National Cooperative**  
2           **Soil Classification;**
- 3           d. Air. Description of any air emissions not normally included in residential  
4           construction and use activities.
- 5
- 6           5. Potable Water. Confirmation of a clean and adequate supply of water to serve the  
7           subdivision; **the location and size of any existing and proposed water mains on**  
8           **the property and adjacent water lines that will provide water supply for the**  
9           **property to be subdivided, as well as details showing connections to water**  
10           **systems; nearest hydrant; Where public water is not to be provided, an**  
11           **alternative means of a clean and adequate water supply shall be shown.**
- 12
- 13           6. Erosion. A soil erosion and sediment control plan prepared and certified by a  
14           professional geologist or professional engineer.
- 15
- 16           7. Traffic. **Locations, widths and names of existing, filed or proposed roads, cross-**  
17           **sections of the proposed grading for roadways, sidewalks, etc. including width,**  
18           **type of pavement, elevations and grades, preliminary designs of any bridges or**  
19           **culverts which may be required, designed to comply with the Road Design and**  
20           **Construction Standards, Sec. 16-3-2;** a traffic study evaluating the capacity of  
21           adjacent roads to safely accommodate the anticipated traffic generated by the  
22           proposed subdivision, including an assessment of the likelihood of cut-through traffic,  
23           efforts to provide for road connectivity, and applicability of the Maine Department of  
24           Transportation regulations.
- 25
- 26           8. Sewage Disposal. **All on site public or shared sewage facilities;** a completed HHE  
27           200 form or other subsurface wastewater design for every lot not served by public  
28           sewer; **all designs, specifications and details for a clustered private or public**  
29           **sewer system.**
- 30
- 31           9. Solid Waste Disposal. Demonstration of adequate capacity for disposal of  
32           construction and solid waste to be generated by the subdivision.
- 33
- 34           10. Aesthetic, cultural and natural information. **Location of scenic, unique natural,**  
35           **farmland, parkland, historic, and significant wildlife habitat areas located on or**  
36           **adjacent to the proposed subdivision,** as well as supporting documentation.
- 37
- 38           11. Local regulations. **The boundaries and designations of zoning districts; applicable**  
39           **space standard and setback provisions, and evaluation of the proposed**  
40           **subdivision's compliance with applicable provisions such as Open Space Zoning**  
41           **(Sec. 19-7-2).**
- 42
- 43           12. Financial and Technical Capability. Statement of Technical and Financial Capability,  
44           including a list of the applicant's development consultants, a description of all prior  
45           development projects, and a letter of firm financial commitment from a bank or other  
46           source of financing. In the case where the applicant asserts that public disclosure of

1 confidential financial information may prove detrimental to the applicant or the  
2 project, the applicant may substitute a recommendation from the Town Manager that  
3 the applicant has adequate financial capability to complete the project.  
4

5 13. Surface Waters. **Location of any portion of the subdivision in the Shoreland**  
6 **Zone; identification of the normal high water line;** assessment of how water  
7 quality will be impacted by anticipated discharge from the subdivision.  
8

9 14. Ground Water. An assessment of how the proposed subdivision will impact  
10 groundwater resources.  
11

12 15. Floodplain. **Location of any portion of the subdivision in the floodplain;**  
13 assessment of how construction in the floodplain will comply with the Town of Cape  
14 Elizabeth Construction Code, Chapter 6, Floodplain Ordinance.  
15

16 16. Wetlands. **The boundaries of all wetlands in accordance with the Zoning**  
17 **Ordinance;** an assessment of how any alterations of wetlands will comply with The  
18 Town of Cape Elizabeth Zoning Ordinance, Chapter 19 wetland regulations, Sec. 19-  
19 6-9.  
20

21 17. Stormwater/Phosporus. **A surface drainage plan or stormwater management plan,**  
22 **with profiles and cross sections drawn by a professional engineer, registered in**  
23 **the State of Maine, showing preliminary design of all facilities and conveyances**  
24 **necessary to meet the stormwater management standards as set forth in this**  
25 **ordinance.** Where the subdivision includes or abuts Great Pond, an assessment of  
26 phosphorus loading amounts and impacts on Great Pond.  
27

28 18. Liquidation Harvesting. **Identification of any portion of the subdivision where**  
29 **timber has been harvested in violation of Title 12, section 8869, subsection 14.**  
30

31 19. Landscaping. **An inventory of existing vegetation to be preserved;** methods of  
32 preserving vegetation to be used during construction; **a landscaping plan including**  
33 **planting locations, plant types, quantities and size and time of planting; fencing**  
34 **location, type and material and size.**  
35

36 20. Open Space. **Designation on the plan of land to be permanently protected as open**  
37 **space; calculation of open space provided to meet the Open Space Impact Fee**  
38 **(Sec. 16-3-1(t)); location of easements;** fee interest or easement deeds of open space  
39 to be conveyed to the Town or otherwise conserved;  
40

41 21. Utilities. Evidence of the capacity to provide electrical and telephone facilities.  
42

43 22. Phasing. **A phasing plan showing the boundaries and name of each phase.**  
44

45 23. Related information. Any other data as determined by the Planning Board to ascertain  
46 compliance with this Ordinance.

1 **Appendix B**

2 **Major Subdivision Submission Requirements**

3 **Preliminary Review**

4 A. General submission parameters

5 An application for preliminary review of a Major Subdivision shall consist of fourteen  
6 (14) sets of plans drawn to a scale of no larger than forty (40) feet to the inch and  
7 supporting materials. The size of the plan sheets submitted to the Planning Board shall be  
8 no larger than twenty-four (24) x thirty-six (36) inches. A digital copy of the complete  
9 application shall also be made available upon request.

10 B. List of submission items

11 The application for preliminary approval of a major subdivision shall include all the  
12 following information. Information that must be shown on a plan is in **bold type**.

- 13
- 14 1. Right, Title or Interest. Evidence of right, title or interest in the site of the proposed  
15 subdivision.
  - 16
  - 17 2. Name of Subdivision/Applicant. **Proposed subdivision name; name and address of**  
18 **record owner and applicant; names of adjoining property owners; date of plan**  
19 **submission, north point and graphic map scale.**
  - 20
  - 21 3. Survey. **A standard boundary survey of the site giving complete descriptive data**  
22 **by bearings and distances, made and certified by a licensed land surveyor; a**  
23 **copy of the deed for the property to be developed, as well as copies of any easements,**  
24 **restrictions or covenants; a plan showing the number of the lot, conceptual**  
25 **dimensions of area and building envelope of each proposed lot sufficient to**  
26 **demonstrate minimum compliance with zoning requirements; existing**  
27 **easements; building lines pertaining to the proposed subdivision and to the**  
28 **adjacent properties; location map, showing the relative location of the**  
29 **proposed project in relation to surrounding neighborhoods or areas of Town;**  
30 **sufficient data to determine readily the location, bearing and length of every lot**  
31 **line and boundary line and to reproduce such lines upon the ground.**
  - 32
  - 33 4. Water Pollution Evaluation.
  - 34
  - 35 a. Topography. **Contour lines at intervals of two (2) feet or at such intervals as**  
36 **the Planning Board may require, based on United States Geological Survey**  
37 **datum and referred to mean sea level;**
  - 38
  - 39 b. Surface drainage. **Surface drainage patterns including drainage channels and**  
40 **watershed areas;** the slope of the land and its effect on effluents; the availability  
41 and condition of streams used for disposal of effluents; an evaluation of  
42 applicable state and local health and water resource rules and regulations.  
43

- 1 c. **Soils. A soils report identifying the soils boundaries and names in the**
- 2 **proposed development with the soils information superimposed upon the plot**
- 3 **plan in accordance with the USDA Soil Conservation Service National**
- 4 **Cooperative Soil Classification.**
- 5
- 6 d. Air. Description of any air emissions not normally included in residential
- 7 construction and use activities.
- 8
- 9 5. Potable Water. Confirmation of a clean and adequate supply of water to serve the
- 10 subdivision; **the location and size of any existing or proposed water mains on the**
- 11 **property and adjacent water lines that will provide water supply for the**
- 12 **property to be subdivided, as well as proposed connections to water systems;**
- 13 **nearest hydrant; where public water is not to be provided, an alternative means**
- 14 **of a clean and adequate supply shall be shown.**
- 15
- 16 6. Erosion. A soil erosion and sediment control plan shall be prepared and certified by a
- 17 professional geologist or professional engineer.
- 18
- 19 7. Traffic. **Location, widths and names of existing, filed and proposed roads;** a
- 20 traffic study evaluating the capacity of adjacent roads to safely accommodate the
- 21 anticipated traffic generated by the proposed subdivision, including an assessment of
- 22 the likelihood of cut-through traffic, efforts to provide for road connectivity, and
- 23 applicability of the Maine Department of Transportation Regulations.
- 24
- 25 8. Sewage Disposal. **All on site public or shared sewage facilities;** a completed HHE
- 26 200 form or other subsurface wastewater design for every lot not served by public
- 27 sewer.
- 28 9. Solid Waste Disposal. Demonstration of adequate capacity for disposal of
- 29 construction and solid waste to be generated by the subdivision.
- 30
- 31 10. Aesthetic, cultural and natural information. **Location of scenic, unique natural,**
- 32 **farmland, parkland, historic and significant wildlife habitat areas located on or**
- 33 **adjacent to the proposed subdivision,** as well as supporting documentation.
- 34
- 35 11. Local regulations. **The boundaries and designations of zoning districts; applicable**
- 36 **space standard and setback provisions of the Zoning Ordinance, and evaluation**
- 37 **of the proposed subdivision's compliance with applicable provisions such as**
- 38 **Open Space Zoning (Sec. 19-7-2).**
- 39
- 40 12. Financial and Technical Capability. Statement of Technical and Financial Capability,
- 41 including a list of the applicant's development consultants, a description of all prior
- 42 development projects, and a letter of firm financial commitment from a bank or other
- 43 source of financing. In the case where the applicant asserts that public disclosure of
- 44 confidential financial information may prove detrimental to the applicant or the
- 45 project, the applicant may substitute a recommendation from the Town Manager that
- 46 the applicant has adequate financial capability to complete the project.

- 1
- 2 13. Surface Waters. **Location of any portion of the subdivision in the Shoreland**
- 3 **Zoning; identification of the normal high water line;** assessment of how water
- 4 quality will be impacted by anticipated discharge from the subdivision.
- 5
- 6 14. Ground Water. As assessment of how the proposed subdivision will impact
- 7 groundwater resources.
- 8
- 9 15. Floodplain. **Location of any portion of the subdivision in the floodplain;**
- 10 assessment of how construction in the floodplain will comply with the Town of Cape
- 11 Elizabeth Construction Code, Chapter 6, Floodplain Ordinance.
- 12
- 13 16. Wetlands. **The boundaries of all wetlands in accordance with the Zoning**
- 14 **Ordinance;** an assessment of how any alterations of wetlands will comply with the
- 15 Town of Cape Elizabeth Zoning Ordinance, Chapter 19, Sec. 19-6-9.
- 16
- 17 17. Stormwater/Phosphorus. A conceptual surface drainage plan or stormwater
- 18 management plan, showing preliminary design of all facilities and conveyances
- 19 necessary to meet the stormwater management standards as set forth in this
- 20 Ordinance. Where the subdivision includes or abuts Great Pond, an assessment of
- 21 phosphorus loading amounts and impacts on Great Pond.
- 22
- 23 18. Liquidation Harvesting. **Identification of any portion of the subdivision where**
- 24 **timber has been harvested in violation of Title 12, section 8869, subsection 14.**
- 25
- 26 19. Landscaping. **An inventory of existing vegetation to be preserved;** methods of
- 27 preserving vegetation to be used during construction; **a conceptual landscaping**
- 28 **plan.**
- 29
- 30 20. Open Space. **Designation on the plan of the land to be permanently protected as**
- 31 **open space; calculation of the open space provided to meet the Open Space**
- 32 **Impact Fee (Sec. 16-3-1(t)); location of easements;** fee interest or easement deeds
- 33 of open space to be conveyed to the Town or otherwise conserved.
- 34
- 35 21. Utilities. Evidence of the capacity to provide electrical and telephone facilities.
- 36
- 37 22. Phasing. A concept phasing plan, if the project will be phased.
- 38
- 39 23. Related Information. Any other data as determined by the Planning Board to ascertain
- 40 compliance with this Ordinance.
- 41
- 42 24. Community Impact Analysis. The Planning Board may require the applicant to
- 43 conduct a community impact analysis which will consist of the following
- 44 demographic features.
- 45



- 1 a. Demographic Description. The analysis must identify the demographic market the  
2 project intends to serve, including:  
3 (1) type of family;  
4 (2) average family size;  
5 (3) number and ages of children; and  
6 (4) anticipated time period to fill all units or lots.

7  
8 Associated data, such as anticipated income levels, type of employment, and  
9 projected housing costs may also be presented to support projections associated with  
10 the above demographic description.

- 11 b. Community Impact Analysis. Utilizing the above demographic data, the applicant  
12 shall conduct analyses of the following:

- 13  
14 (1) Estimated impact of traffic systems, including the impact of projects trips on  
15 flow characteristics and the impact of traffic on the immediate, existing road  
16 structures;  
17 (2) Estimated impact on the school system;  
18 (3) Estimated impact on public safety providers;  
19 (4) Estimated impact on the public works department, including solid waste  
20 disposal;  
21 (5) Estimated impact on existing storm water management systems including  
22 flow and water quality;  
23 (6) Estimated impact on the recreation resources and provision of methods to  
24 meet proposed needs;  
25 (7) Estimated impact on wildlife habitat areas;  
26 (8) Impact on the stated goals and objectives of the Comprehensive Plan; and  
27 (9) Any other study deemed appropriate by the Planning Board.

28  
29 Once these analyses have been completed, the applicant shall present this information  
30 and impact assessments to the Planning Board for its review and comment.

### 31 **Final Review**

- 32 A. General submission parameters. Same as for Preliminary Review.  
33 B. List of submission items  
34 1. Preliminary Approval. All information required to be shown on the preliminary plans,  
35 with all amendments required by the Planning Board and other reviewing agencies  
36 and those suggested by the Planning Board and adopted by the applicant, and further  
37 augmented as follows:  
38 2. Survey. **Final plan showing the number of the lot, final calculations of lot area,**  
39 **property line dimensions and building envelope for each proposed lot.**  
40  
41 3. Potable Water. **The preliminary plan approved by the Planning Board for water**  
42 **supply supplemented to include final design, details and specifications of**  
43 **installation and connection to existing water mains.**

- 1
- 2 4. **Traffic. The preliminary plan approved by the Planning Board for road access**
- 3 **and traffic supplemented to include final design, details and specifications of**
- 4 **proposed roads, driveways as needed, and connections to existing roads.**
- 5
- 6 5. **Sewage Disposal. The preliminary plan approved by the Planning Board for**
- 7 **public or private cluster sewage system supplemented to include final design,**
- 8 **details, and specifications of proposed sanitary waste infrastructure and**
- 9 **connections to public sewer lines.**
- 10 6. **Local regulations. The preliminary plan approved by the Planning Board**
- 11 **updated to reflect any changes to how the project complies with local**
- 12 **regulations.**
- 13 7. **Financial Capability. Performance guarantee estimate with detail of unit cost and**
- 14 **quantity for the subdivision, segmented into phases if the proposed subdivision will**
- 15 **be phased; draft performance guarantee document including issuing agent.**
- 16 8. **Stormwater/Erosion. The preliminary plan approved by the Planning Board for**
- 17 **stormwater management and erosion control supplemented to include final**
- 18 **design, details, and specifications of the proposed stormwater infrastructure and**
- 19 **any connections to existing stormwater facilities.**
- 20
- 21 9. **Landscaping. The preliminary plan approved by the Planning Board for**
- 22 **landscaping supplemented to include final design, details and specifications**
- 23 **including but not limited to a detailed planting plan showing vegetation to be**
- 24 **preserved, preservation plan, new planting locations, planting types, quantities**
- 25 **and size at time of planting, fencing location, type, size and materials.**
- 26 10. **Open Space. The preliminary plan approved by the Planning Board for open space**
- 27 **preservation supplemented by draft written conservation restrictions, easement deeds,**
- 28 **survey descriptions, and any other documentation.**
- 29
- 30 11. **State and Federal permits. Written evidence of the issuance of all permits, licenses**
- 31 **and approvals required for the subdivision from any federal, state or other local**
- 32 **agency.**
- 33
- 34 12. **Conditional Municipal Approval. Written evidence of (i) the offer and conditional**
- 35 **municipal approval by the Town Council of all roads, sewer lines, drainage**
- 36 **easements, proposed public open space, recreation land, and other such common**
- 37 **areas and facilities proposed to be dedicated to the Town; or (ii) satisfactory**
- 38 **agreements or other documents showing the manner in which private roads, sewer**
- 39 **lines and systems, drainage ways, open space, recreation land, and other such**
- 40 **common areas and facilities are to be maintained. Written agreements of a dedication**
- 41 **to a third party other than the Town must also be submitted and deemed satisfactory**
- 42 **by the Planning Board.**
- 43

- 1 13. Phasing Plan. **If the subdivision will be constructed in phases, the phasing plan**  
2 **shall show the entire subdivision and every part of the subdivision shall be**  
3 **assigned to a phase.** The plan shall also identify the sequence of construction of  
4 phases and **show how utilities, emergency vehicle access, turnaround space and**  
5 **any other element of the development that will be impacted by phasing will be**  
6 **accommodated for each phase.**  
7
- 8 13. Recording Plat. **A Subdivision Plat suitable for recording which includes a**  
9 **prominent notation that there shall be no sale of lots, nor issuance of building**  
10 **permits, nor site work commenced until the required performance guarantee**  
11 **has been approved in accordance with Sec. 16-2-6(c) of this Ordinance.**

## Appendix C Road Tree List

The following trees are recommended for planting to meet the road tree requirements. Alternative species may also be acceptable upon approval of the Tree Warden, unless specified by the Planning Board. The list includes the scientific and common tree name, minimum required caliper at the time of planting, expected height at maturity and comments. The comments refer to tree characteristics of water and salt tolerance.

<b>Scientific</b>	<b>Common</b>	<b>Size</b>	<b>Height</b>	<b>Comments*</b>
Acer campestre	Hedge Maple	2"	45'	D,M
Acer saccharum	Sugar Maple	2"	80'	WD
Acer pseudoplatanus	Planetree maple	2"	60'	WD,H
Acer rubrum	Red Maple Cultivars	2"	60'	W,M
Betula alleghaniensis	Yellow Birch	2"	50'	W
Carpinus caroliniana	American Hornbeam	2"	30'	W
Cercidiphyllum japonicum	Katsura	2"	60'	W
Cladrastus kentuckea	Yellowwood	2"	60'	W
Corylus colurna	Turkish Filbert	2"	50'	D
Ginkgo biloba	Maidenhair Tree Cultivars	2"	60'	D,M
Maackia amurensis	Maackia	2"	40'	W
Nyssa sylvatica	Tupelo	2"	60'	W
Platanus acerfolia	London Plane	2"	75'	W
Quercus bicolor	Swamp White oak	2"	55'	W
Quercus rubra	Red Oak	2"	75'	D
Quercus spp	Other oak species as approved by Tree Warden	2"		
Sorbus alnifolia	Korean Mountain Ash	2"	35'	D,M
Syringa reticulata	Japanese Tree Lilac	2"	30'	D,M
Zelkova serrata	Zelkova	2"	50'	W
Native species	as approved by Tree Warden	2"		

\* W= Wet, D=Dry, WD=Well Drained, M=Moderate Salt Tolerance and H= High Salt Tolerance

All trees shall be planted in accordance with the Planting Specifications of the Cape Elizabeth Comprehensive Street Tree Plan.

1  
2  
3  
4

Appendix D  
Turnaround Designs  
Page 1 of 2

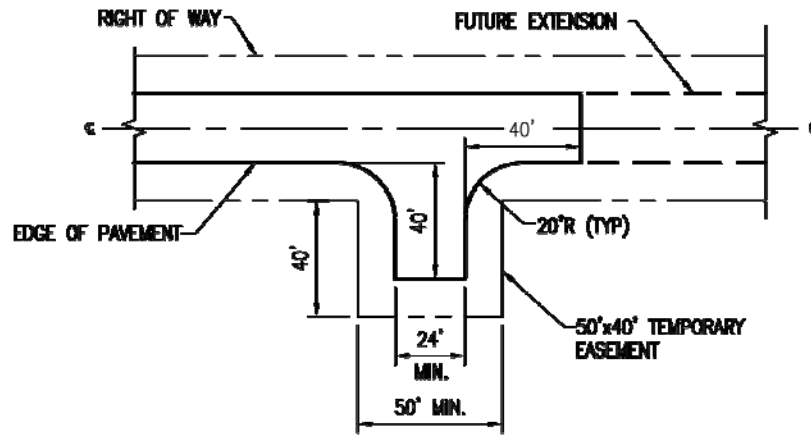

ALTERNATE #1

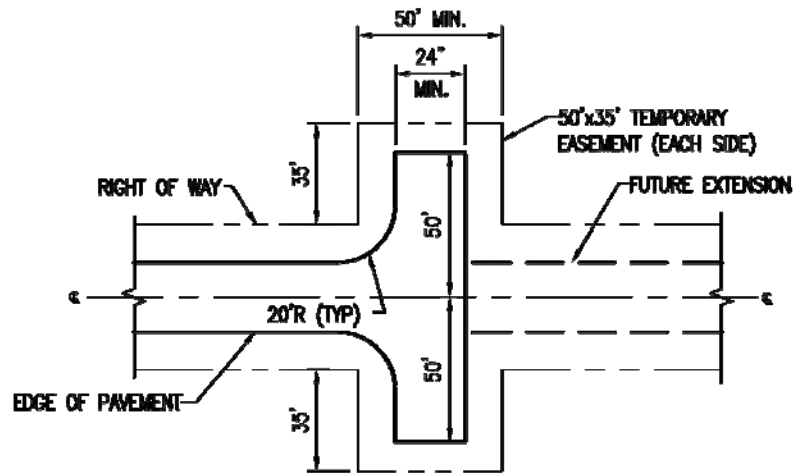

ALTERNATE #2

MINIMUM DIMENSIONS  
TURN-AROUNDS  
NOT TO SCALE

5  
6

1  
2  
3  
4  
5  
6

Appendix D  
Turnaround Designs,  
Page 2 of 2

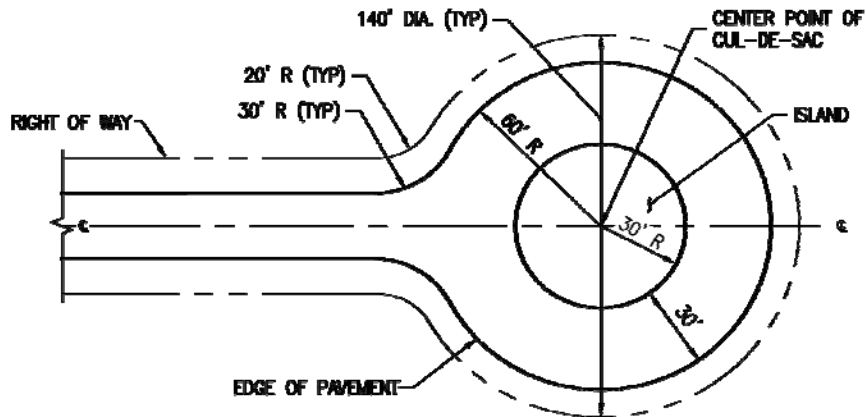

MINIMUM DIMENSIONS  
CUL-DE-SAC WITH ISLAND  
NOT TO SCALE

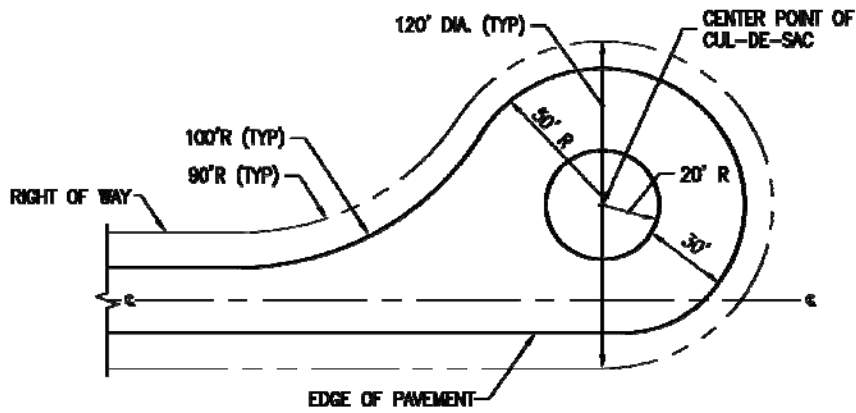

MINIMUM DIMENSIONS  
CUL-DE-SAC WITH ISLAND  
NOT TO SCALE

7  
8

1  
2  
3  
4

### Appendix E Road Cross Sections Local Road

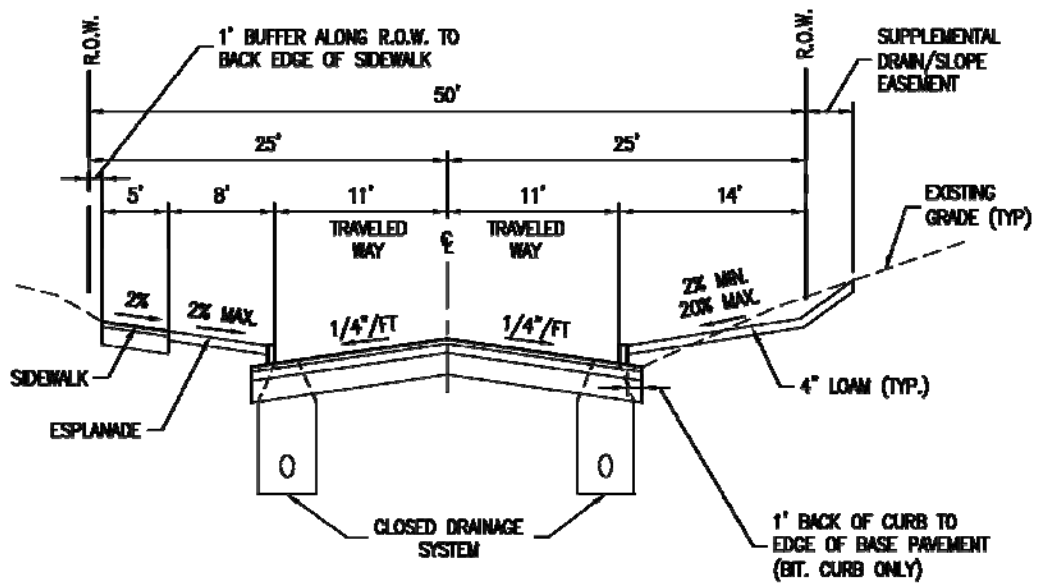

NOTE:  
SEE ROAD CLASSIFICATION STANDARDS TABLE

LOCAL ROAD  
NOT TO SCALE

5  
6  
7

1  
2  
3  
4  
5

### Appendix E Road Cross Sections Feeder Road

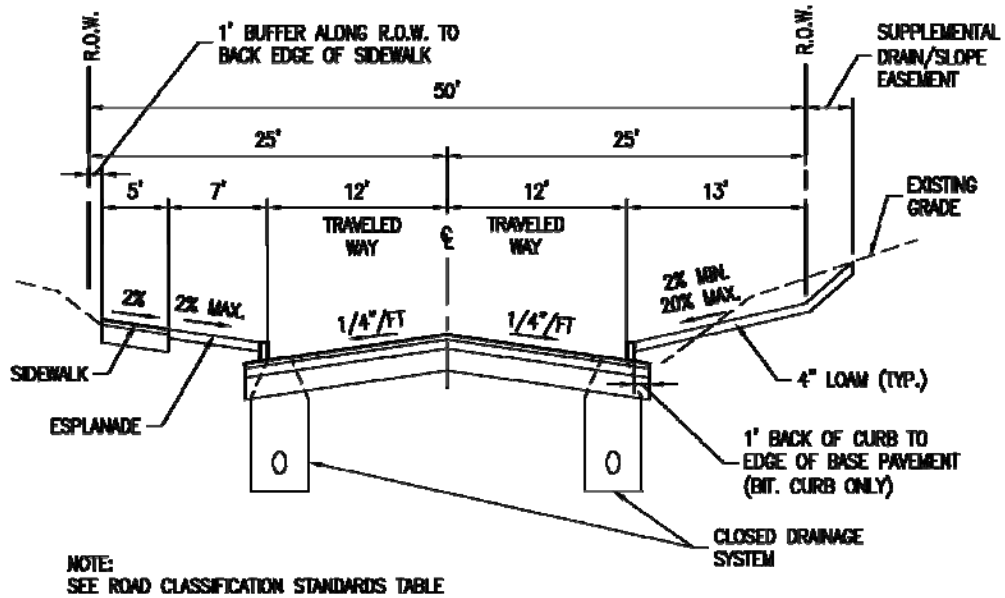

**FEEDER ROAD**  
NOT TO SCALE

6  
7



1  
2  
3  
4  
5  
6  
7  
8

### Appendix E Road Cross Sections Collector Road

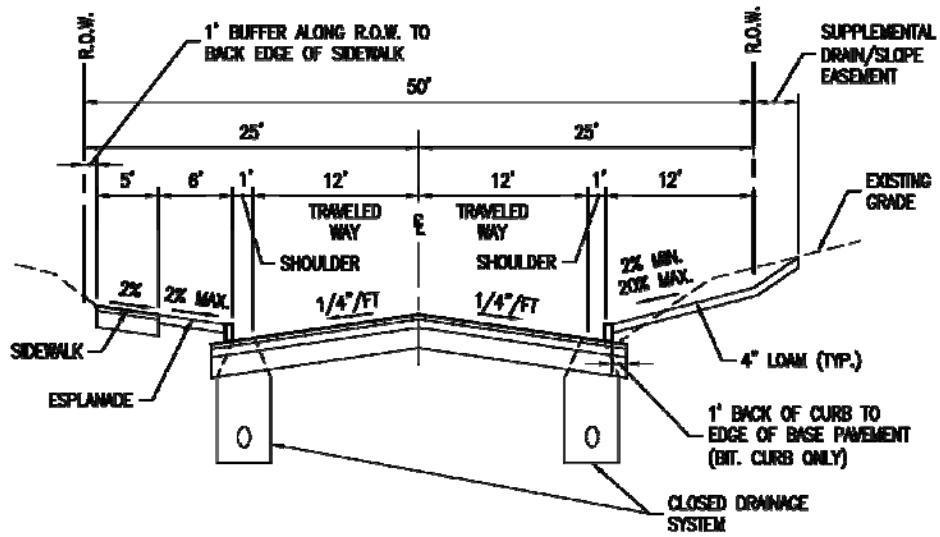

NOTE:  
SEE ROAD CLASSIFICATION STANDARDS TABLE

COLLECTOR ROAD  
NOT TO SCALE

9  
10

1  
2  
3  
4  
5  
6  
7

### Appendix E Road Cross Sections Rural Connector

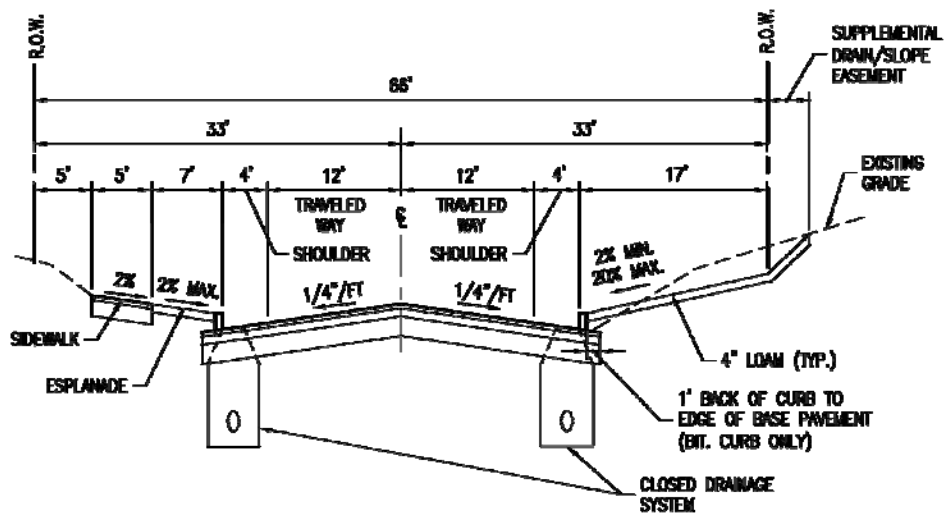

NOTE:  
SEE ROAD CLASSIFICATION STANDARDS TABLE

**RURAL CONNECTOR ROAD**  
NOT TO SCALE

8  
9  
10  
11

1  
2  
3  
4  
5  
6  
7

### Appendix E Road Cross Sections Arterial Road

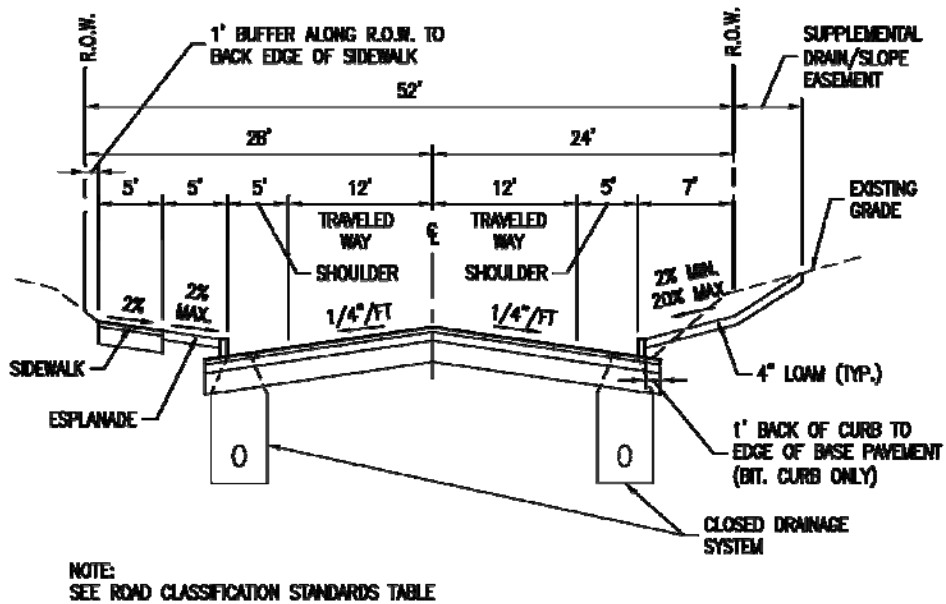

**ARTERIAL ROAD**  
NOT TO SCALE

8

